

CO₂ Recovery

ASCO CO₂ Stack Gas Recovery Systems (SGR)



ASCO's innovative ASCOSORB CO₂ Stack Gas Recovery Technology turns your vent flue gas into a usable and profitable source of CO₂.

CO₂ gas won by a **ASCO** Stack Gas Recovery System is a by-product of flue gas production from boilers as well as from other flue gas sources offering an economic CO₂ source to any CO₂ consumer or reseller. **ASCO**, as a provider of complete CO₂ solutions, offers CO₂ Stack Gas Recovery Systems with various capacities.

The revolutionary **ASCOSORB CO₂ Stack Gas Recovery Technology** features the following **key benefits**:

- Reliable and economic source of CO₂ to the end user as opposed to self burning processes or purchasing liquid CO₂
- **The ASCOSORB Technology brings to the ASCO CO₂ Stack Gas Recovery Plant tremendous reduction in total energy usage offering greatly reduced OPEX: only approx. 0.8 - 1.3 MW_{th}/MT produced CO₂**
- The **ASCOSORB** Technology brings to the CO₂ stack gas recovery plant innovations such as **reduced solvent consumption** again contributing reduced operating cost to the already reduced OPEX
- The specially formulated **ASCOSORB** solvent utilized with the **ASCO** CO₂ Stack Gas Recovery System is **resistant to any level of oxygen** typical of flue gas sources allowing greater system efficiencies and longevity of the plant
- Liquid CO₂ quality produced by an **ASCO** CO₂ Stack Gas Recovery System **meets specifications of ISBT**, food and beverage, and customer final liquid quality specifications
- **ASCO** CO₂ Stack Gas Recovery Systems offer a **capacity range from 500 to 50'000 kg/h (1'100 to 110'000 lb/h)**

ASCO's CO₂ Stack Gas Recovery Technology extracts nearly the total volume of CO₂ gas content in flue gas streams. Key is the specially formulated **ASCOSORB** extraction solvent which provides the CO₂ Stack Gas Recovery Plant with reduced OPEX as a result of its CO₂ gas extraction and loading capability compared to other competitive solvent mixtures. This technology not only offers the end user a reliable CO₂ source but as well considered by many a green approach to the overall concept to CO₂ gas recovery. Combined with the specially formulated **ASCOSORB** Solvent, the ASCO CO₂ Stack Gas Recovery System utilizes stainless steel process towers and pumps to ensure long and effective equipment life and reliable performance for years to come.

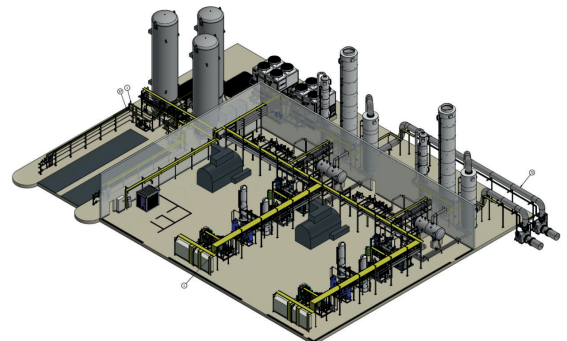

ASCO CO₂ Stack Gas Recovery Systems: Features

Feature	Benefit
Stainless steel construction	Long plant longevity
Low energy consumption	Low OPEX
Integrated amine recovery	Contributing to the already reduced OPEX
High CO ₂ extraction	Low carbon foot print
Retrofits easily to existing CO ₂ production plants	Modernize your existing plant by eliminating fuel burning and saving up to 70 % production costs.
Flexible layout	Compact, modular component design means fast and easy installation and provides an economical use of available space, covering a variety of different layouts.
Inline scrubber water recirculation and treatment system	Designed to handle all the process scrubbing water, this system recycles, neutralises and sheds the process heat from the water all in one circuit. This significantly reduces the volume of water discharged to drain, providing an economical and environmentally friendly water system.
Process towers location	Option of indoor or outdoor installation of all process towers allows flexibility of layout in a variety of different situations. Outdoor location also reduces the required weather protection for the system.
Oilfree CO ₂ compressor	Specially designed for use with CO ₂ gas, the oilfree compressor means there is no possibility of CO ₂ contamination with oil.
High pressure stainless steel purifier	Longer residence time provides ultra-efficient NO _x and H ₂ S removal.
Carbon filter	A high capacity carbon filtration column is installed in the CO ₂ gas inlet line to the liquefier, to provide further assurance of pure and odour-free CO ₂ .
Centralized control panel	Automatic plant operation and visual display (HMI) provide one touch read-outs of process data from a centralized position.



Process unit with reboiler

ASCO CO₂ Stack Gas Recovery Systems

General process description

Flue gas from boiler exhausts (be it existing, new or even power generators) contain combustion products like CO₂, water vapor, N₂, O₂, CO, and possibly SO₂ depending on the fuel being used. This flue gas, under the **ASCOSORB** process, is first cooled and treated for SO₂ effectively rendering a flue gas to a proper operating temperature and reaching an acceptable level of SO₂ prior to entering the **ASCOSORB** process of CO₂ Gas extraction.

Once cooled and treated the flue gas enters the CO₂ stack gas recovery system for extraction of CO₂ gas from the flue gas, using specially formulated **ASCOSORB** absorption solvent combined with process towers and packing for best overall efficiency. These towers include the CO₂ gas absorber and CO₂ stripper. It's the combination of the specially formulated **ASCOSORB** solvent and the optimized packing technology that gives the extraction process the efficiency to nearly extract all the CO₂ present in the flue gas as well as be resistant to any level of O₂ present in the source stream. Once absorbed, the CO₂ gas is carried away within the special **ASCOSORB** solvent, and remaining products of combustion are vented off the top of the absorber tower. The solvent, enriched with CO₂, is passed to the stripper tower which uses reboiled lean solvent combined with tower and structured packing material to liberate the CO₂ gas from the enriched solvent stream. The exit CO₂ gas from the stripper is at a controlled temperature and pressure ready for further processing.

CO₂ gas processing from the **ASCO** CO₂ Stack Gas Recovery System is completed with the efficient and high quality supply of **ASCO** compression, purification, drying and liquefaction equipment typical of supply with our production and by-product recovery plants. This ensures the liquid CO₂ produced from the total **ASCO** CO₂ Stack Gas Recovery Plant exceeds the parameters set forth by many customers and industry standards.

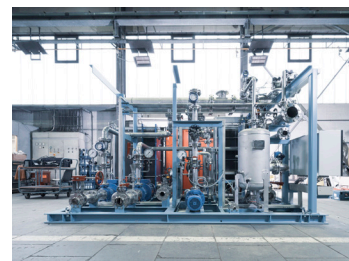

Process unit



Absorber and Desorber

Capacities

Available standard capacities: 500 to 2'000 kg/h (1'100 to 4'400 lb/h)

Individually engineered plants available for capacities up to 50'000 kg/h (110'000 lb/h)

Utility Consumptions

Thermal energy consumption: only approx. 0.8 - 1.3 mW_{th}/MT produced CO₂

Complete information of utility consumptions provided with each **ASCO** proposal for a CO₂ Stack Gas Recovery System.

ASCO CO₂ Stack Gas Recovery Systems

Standard Layout Proposal dimensions in mm (in)				
Capacity	A	B	C	D
500 kg/h (1'100 lb/h)	20'000 (787)	17'000 (670)	12'000 (472)	6'000 (236)
1'000 kg/h (2'200 lb/h)	21'300 (838)	18'300 (720)	14'150 (557)	6'000 (236)
1'500 kg/h (3'300 lb/h)	30'000 (1'181)	25'000 (984)	17'500 (689)	6'500 (256)
2'000 kg/h (4'400 lb/h)	34'500 (1'358)	28'500 (1'122)	18'000 (708)	7'000 (275)
> 2'000 kg/h (4'400 lb/h)	Customer-specific			

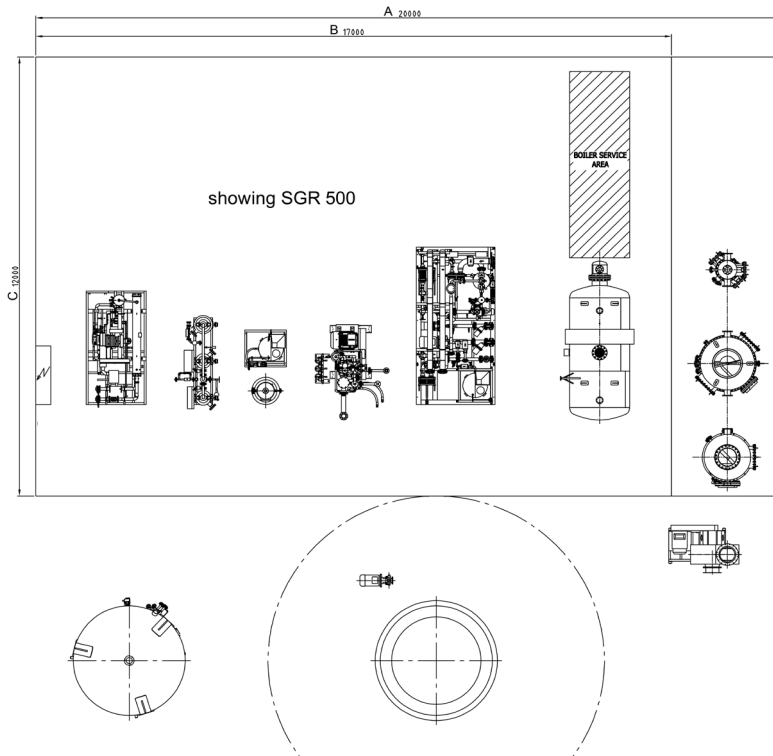
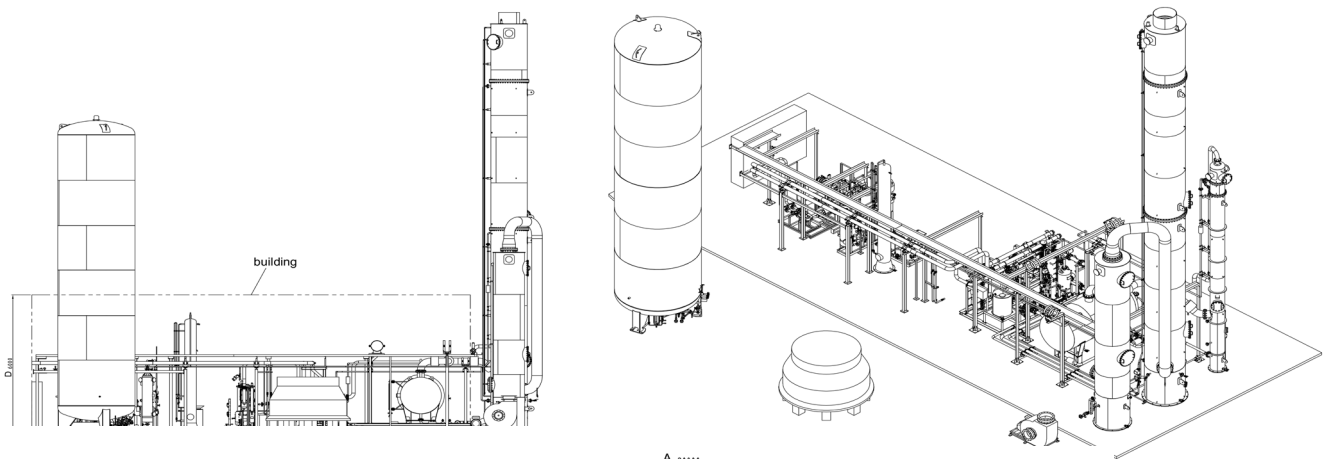

Subject to technical changes / improvements