

The logo for ASCO, featuring a stylized blue 'A' with three horizontal lines to its left, followed by the letters 'ASCO' in a bold, blue, sans-serif font.

All about CO<sub>2</sub>

# Product Catalogue

The Complete CO<sub>2</sub> Solution  
Version 4.9

[ascoco2.com](http://ascoco2.com)



# Table of Contents

<b>General Information about CO<sub>2</sub></b>	<b>4</b>
<b>CO<sub>2</sub> Recovery</b>	<b>8</b>
• ASCO CO <sub>2</sub> Stack Gas Recovery Systems (SGR) .....	8
• ASCO CO <sub>2</sub> By-Product Recovery Systems (BPR).....	12
• ASCO CO <sub>2</sub> Gas Revert Recovery Systems (RRSi) .....	14
<b>CO<sub>2</sub> Storage</b>	<b>20</b>
• ASCO CO <sub>2</sub> Storage Tanks Vacuum Insulated.....	20
• ASCO CO <sub>2</sub> Storage Tanks Polyurethane Insulated.....	33
• ASCO 20' ISO Tank Containers .....	42
• ASCO Transportable CO <sub>2</sub> Tanks / ASCO CO <sub>2</sub> Semi-Trailers.....	47
<b>CO<sub>2</sub> Gas Dosing for Water Neutralisation</b>	<b>49</b>
• ASCO CO <sub>2</sub> Gas Dosing Systems.....	49
<b>CO<sub>2</sub> Vaporising</b>	<b>54</b>
• Atmospheric ASCO CO <sub>2</sub> Vaporiser .....	54
<b>CO<sub>2</sub> Cylinder Filling</b>	<b>60</b>
• ASCO CO <sub>2</sub> Cylinder Filling System LH900 .....	60
<b>CO<sub>2</sub> Transfer Pumps</b>	<b>63</b>
• ASCO CO <sub>2</sub> Transfer Pumps: Low to Low Pressure .....	63
<b>CO<sub>2</sub> Testing Equipment</b>	<b>66</b>
• ASCO CO <sub>2</sub> Gas Purity Tester .....	66
• ASCO CO <sub>2</sub> Carbonation Tester Type III .....	68
• ASCO CO <sub>2</sub> Dew Point Tester .....	69
<b>CO<sub>2</sub> Equipment</b>	<b>70</b>
• ASCO CO <sub>2</sub> Flowmeter .....	70
• ASCO CO <sub>2</sub> Cylinder Valve .....	72
• ASCO Line Safety Assembly .....	73
• ASCO CO <sub>2</sub> Pressure Reducing Valve .....	74
<b>Safety</b>	<b>76</b>
• ASCO CO <sub>2</sub> Gas Detectors .....	76
<b>Dry Ice Storage</b>	<b>78</b>
• ASCO Dry Ice Box AT126 .....	78
• ASCO Dry Ice Container AT240W .....	79
• ASCO Dry Ice Container AT440.....	80

<b>Dry Ice Production</b>	<b>81</b>
• ASCO Dry Ice Pelletizer P15i-D3.....	81
• ASCO Dry Ice Pelletizer P28i-D3.....	84
• ASCO Dry Ice Pelletizer P55i .....	87
• ASCO Dry Ice Pelletizer P75i .....	90
• ASCO Automatic Dry Ice Machine BP420i .....	94
• ASCO Automatic Dry Ice Machine BP425i .....	98
• ASCO Dry Ice Reformer R70i.....	102
<b>Dry Ice Production / Sawing</b>	<b>105</b>
• ASCO Dry Ice Active Saw - AAS.....	105
<b>Dry Ice Production / Wrapping</b>	<b>107</b>
• ASCO Automatic Wrapping Machine APM120.....	107
<b>Dry Ice Production / Bagging</b>	<b>110</b>
• ASCO Pellets Bagging Machine PBM .....	110
<b>Dry Ice Production / Dosing</b>	<b>113</b>
• ASCO Dry Ice Refilling System ARS .....	113
<b>ASCO Dry Ice Blasting Technology</b>	<b>116</b>
• General Information .....	116
• ASCOJET 1208.....	126
• ASCOJET 1701.....	131
• ASCOJET 1708 Combi Blaster .....	138

**ASCO reserves the right to modify all specifications without prior notice.**

**All photos and drawings are used for marketing purposes only.**

# General Information about CO<sub>2</sub>

## What is CO<sub>2</sub>?

Carbon dioxide is the combination of two atoms of oxygen joined with a single atom of carbon. Its chemical formula CO<sub>2</sub>, is almost as well known as that of water, H<sub>2</sub>O and it is frequently referred to by its formula rather than its name.

In nature's chain of life, the mutual dependence of plant and animal life is maintained through the link of carbon dioxide. Every time we breathe we release this gas, which plants need for life. Through the process of photosynthesis, the plants separate the carbon from the oxygen. In turn, plants release the pure oxygen, which we need to survive. We reverse the process, and by combining the oxygen with carbon from the foods we eat, produce carbon dioxide again.

CO<sub>2</sub> is a colourless, inert gas approximately 1½ times heavier than air and 0.03 % is present in the earth's atmosphere. It is odorless, has a sweet biting taste (soda water) and is highly stable (difficult to separate).

It is produced in varying amounts by the common process of combustion of fuels high in carbon content. The most common source of fuel for combustion is oil which, when mixed with the correct proportion of air, burns to produce around 15 % CO<sub>2</sub> in the flue gases of a CO<sub>2</sub> plant. After combustion has taken place, the CO<sub>2</sub> can be separated from the flue gases and, through a simple process, made available for the many commercial purposes to which it can be applied.

CO<sub>2</sub> can exist in three forms:

- in gaseous form: for the beverage and food industries
- in liquid form: in a storage tank under pressure
- in solid form: called dry ice (for cooling, blasting etc.)

**GASEOUS CO<sub>2</sub>** can be liquefied under pressure provided its temperature is below 31 °C, this temperature being referred to as the **CRITICAL POINT**. If compressed and cooled below the critical point, a colourless fluid, approximately the same density as water, is produced.

CO<sub>2</sub> will remain in the liquid form as long as its temperature remains below the critical point but will return to the gaseous state if its temperature rises above this point, regardless of the pressure applied.

**LIQUID CO<sub>2</sub>** can be stored indefinitely at

High pressure  
or  
Low pressure

as follows:

### High Pressure CO<sub>2</sub>

High pressure liquid CO<sub>2</sub> is produced by compressing the gaseous CO<sub>2</sub> in multistage compressors to pressures in the neighbourhood of 69 bar (1000 psi) pressure, then cooling it to around 18 °C. It is customarily filled into specially constructed steel cylinders. Like water, liquid CO<sub>2</sub> can be weighed, and this is the normal form of measuring it.

### Low Pressure CO<sub>2</sub>

Low pressure liquid is an alternative method of storing CO<sub>2</sub> and is produced either by expanding high pressure CO<sub>2</sub> to a lower pressure or by refrigeration. It is held in specially constructed storage tanks, heavily insulated and equipped with refrigeration units to hold the internal tank pressure at or below 21 bar (305 psi) and -18 °C temperature. Pressure switches are incorporated to control the refrigeration units and safety mechanism and electrical alarms are fitted to release the tank pressure and raise an alarm in the event of refrigeration malfunction.

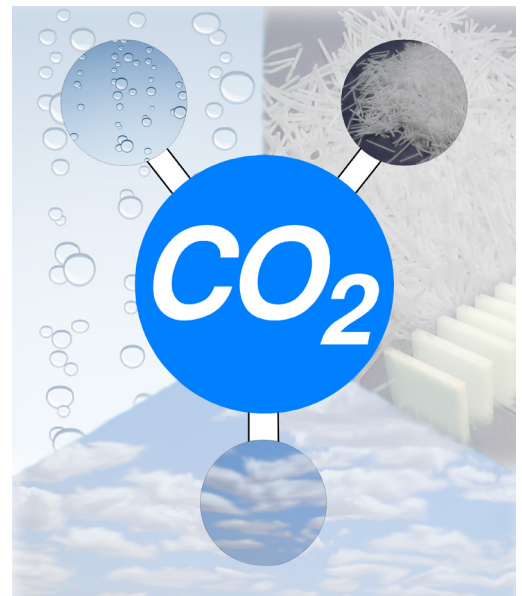

# General Information about CO<sub>2</sub>

Low pressure liquid CO<sub>2</sub> (sometimes referred to as “bulk”) is transported to one place from another in insulated road tankers or trailers (or, in some countries, by rail tank wagons), the liquid being simply transferred from mobile to static tank by pumping or gravity feed.

Unlike water, carbon dioxide cannot exist in the open air in liquid form. It must be held under pressure or refrigeration (or a combination of both) to remain in the liquid state.

## **SOLID CO<sub>2</sub> (customarily known as “DRY ICE”)**

Dry ice is the product of processing liquid CO<sub>2</sub>. If the pressure of liquid CO<sub>2</sub> is suddenly released, a proportion of that liquid will change to the solid state (becoming dry ice “snow”) and the remainder will revert to gas (revert gas). When the snow is compressed under hydraulic or mechanical action, blocks or pellets of dry ice are formed. The revert gas (gaseous CO<sub>2</sub>) can be readily reclaimed and converted back to liquid by recompression and reliquefaction, thence returned to the dry ice block machine or pelletizer for further processing.

The temperature of dry ice is -79 °C and in the atmosphere it will pass directly from the solid to the gaseous stage, leaving no moisture or trace of its presence except the cold.

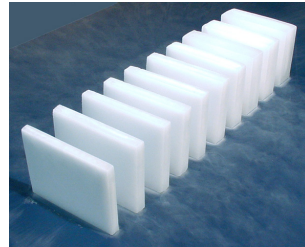

## CO<sub>2</sub> is our Life

---

Many generations - and individual lifetimes! - of experience have perfected **ASCO**'s ability to provide the most complete and best matched CO<sub>2</sub> system available.

From the CO<sub>2</sub> production or recovery plant to storage, dry ice blasting, cylinder filling, dry ice making and even dry ice wrapping, it's all **ASCO**. This ability to provide matched components benefits **ASCO** clients as they can comfortably develop and grow their business without changing suppliers.

Having the largest range of CO<sub>2</sub> and dry ice components also enables **ASCO** customers to make full use of the versatile nature of CO<sub>2</sub> and its vast number of uses, thus gaining maximum value from the product. For example a soft drink bottler could easily develop an extra cash flow business from surplus CO<sub>2</sub> (or excess plant capacity) by adding **ASCO** dry ice equipment and / or cylinder filling gear to supply CO<sub>2</sub> to other users.

**ASCO**'s website provides details of their most up to date CO<sub>2</sub> and dry ice plants. All **ASCO** equipment is space efficient, designed for easy operation, maintenance and engineered for maximum reliability and life. Component materials are selected to balance capital cost and plant longevity and from the flue gas oxygen sensor on the plant to the level indicator on the CO<sub>2</sub> storage tank all controls are effective, logical, clear, and linked to a PLC.

**ASCO**'s technology, combined with a wide range of CO<sub>2</sub> equipment, makes it easy for their clients to mix and match components and thus tailor their CO<sub>2</sub> / dry ice system from the one shop.

Significant new **ASCO** CO<sub>2</sub> plant sales to Africa, South America and the Middle East indicates that many bottlers, brewers and merchant CO<sub>2</sub> companies prefer working with a single supplier and that supplier is **ASCO**. Let our life add life to your business.

# General Information about CO<sub>2</sub>

## From Liquid CO<sub>2</sub> into Dry Ice

Carbon Dioxide has 3 physical states of gas, liquid and solid which depend on temperature and pressure.

The relationship between the 3 states is shown on the pressure-temperature phase diagram beside.

## Where does CO<sub>2</sub> come from?

CO<sub>2</sub> is derived from a number of sources including combustion of carbonaceous fuels, fermentation, natural wells, and as a by-product of industrial processes such as ethylene oxide and bioethanol production and ammonia synthesis.

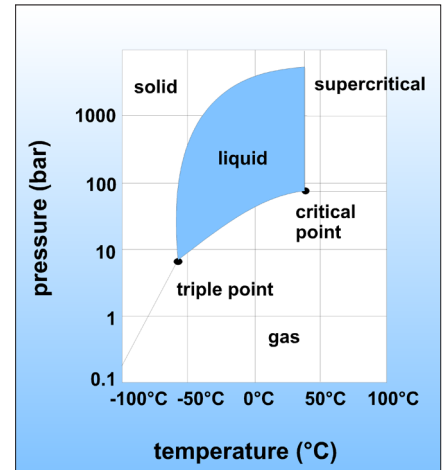

CO<sub>2</sub> phase diagram

## The Solid State (Dry Ice)

Below the triple point (5.2 bar (75 psi) , -56.6°C) CO<sub>2</sub> can only appear in its solid and gaseous state. Dry Ice is the common trade name for solid CO<sub>2</sub>. At atmospheric pressure it has a temperature of approx. -79°C. The solid CO<sub>2</sub> changes directly into its gaseous state. This evaporation (sublimation) does not leave any residues. Dry ice is non-toxic, non-inflammable, inert, without smell and bacteriostatic. It is white and has a density of approx. 1'500 kg/m<sup>3</sup> (93.6 lb/ft<sup>3</sup>) in its compact state. Dry ice is an ideal refrigerant which qualifies especially well for various applications. It has a high cooling capacity and heat transfer is very high when in direct contact with the cold material.

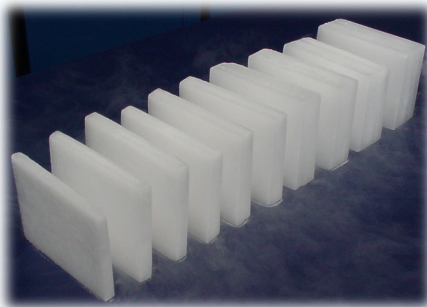

Dry ice slices and blocks



16 mm (5/8 ") pellets



3 mm (1/8 ") pellets

**ASCO** has the best range of dry ice machines for dry ice production.

## The Liquid State

Within a temperature range between -56.6°C and 31°C and pressure greater than 5.2 bar (75 psi) and less than 74 bar (1073 psi) respectively CO<sub>2</sub> is in its liquid state except at very high pressures. This means that, below 5.2 bar (75 psi), CO<sub>2</sub> exists only in its solid or gaseous state. At 5.2 bar (75 psi) and -56.6°C all three states (solid, liquid and gas) are present. This is called the triple point.

# General Information about CO<sub>2</sub>

The critical point of CO<sub>2</sub> lies at a temperature of approx. 31 °C and a pressure of approx. 74 bar (1073 psi). Normal CO<sub>2</sub> liquid can only be formed at temperatures below 31 °C. Above the critical point there is no physical difference between the liquid and gaseous phase. This supercritical state is also called „Fluid“. The liquid state is important for the storage and transportation of CO<sub>2</sub> as well as during cooling and freezing applications. During release of the liquid CO<sub>2</sub> to atmosphere a temperature of -79 °C is reached. This is associated with a high cooling capacity due to the evaporation heat which is extracted from the environment when releasing the liquid CO<sub>2</sub>.



Horizontal CO<sub>2</sub> storage tank



Vertical CO<sub>2</sub> storage tank



ISO container for transportation of CO<sub>2</sub>

## The Gaseous State

CO<sub>2</sub> gas has a density of approx. 1.9kg/m<sup>3</sup> (0.12lb/ft<sup>3</sup>) at atmospheric pressure and +15 °C. CO<sub>2</sub> has many unique and beneficial features which make it valuable in the preservation of packaged food, in explosion and fire protection, in pest control and as protective gas in inert-gas-welding. In all these applications it is important for the CO<sub>2</sub> gas to drive out and replace the atmospheric oxygen. Moreover, CO<sub>2</sub> gas is used for enriching the atmosphere in greenhouses, in storing fruits and vegetables and for pH control when treating potable and waste water.



CO<sub>2</sub> for beverage carbonation



CO<sub>2</sub> fumigation in pest control

[www.ascoco2.com](http://www.ascoco2.com)

provides details of our most up to date CO<sub>2</sub> and dry ice plants. All ASCO equipment is space efficient, designed for easy operation and maintenance and engineered for maximum reliability and life.

# CO<sub>2</sub> Recovery

## ASCO CO<sub>2</sub> Stack Gas Recovery Systems (SGR)



**ASCO's innovative ASCOSORB CO<sub>2</sub> Stack Gas Recovery Technology turns your vent flue gas into a usable and profitable source of CO<sub>2</sub>.**

CO<sub>2</sub> gas won by a **ASCO** Stack Gas Recovery System is a by-product of flue gas production from boilers as well as from other flue gas sources offering an economic CO<sub>2</sub> source to any CO<sub>2</sub> consumer or reseller. **ASCO**, as a provider of complete CO<sub>2</sub> solutions, offers CO<sub>2</sub> Stack Gas Recovery Systems with various capacities.

The revolutionary **ASCOSORB CO<sub>2</sub> Stack Gas Recovery Technology** features the following **key benefits**:

- Reliable and economic source of CO<sub>2</sub> to the end user as opposed to self burning processes or purchasing liquid CO<sub>2</sub>
- **The ASCOSORB Technology brings to the ASCO CO<sub>2</sub> Stack Gas Recovery Plant tremendous reduction in total energy usage offering greatly reduced OPEX: only approx. 1.3 MW<sub>th</sub>/MT produced CO<sub>2</sub>**
- The **ASCOSORB** Technology brings to the CO<sub>2</sub> stack gas recovery plant innovations such as **reduced solvent consumption** again contributing reduced operating cost to the already reduced OPEX
- The specially formulated **ASCOSORB** solvent utilized with the **ASCO** CO<sub>2</sub> Stack Gas Recovery System is **resistant to any level of oxygen** typical of flue gas sources allowing greater system efficiencies and longevity of the plant
- Liquid CO<sub>2</sub> quality produced by an **ASCO** CO<sub>2</sub> Stack Gas Recovery System **meets specifications of ISBT**, food and beverage, and customer final liquid quality specifications
- **ASCO** CO<sub>2</sub> Stack Gas Recovery Systems offer a **capacity range from 500 to 2'000 kg/h (1'100 to 4'400 lb/h)**

**ASCO's** CO<sub>2</sub> Stack Gas Recovery Technology extracts nearly the total volume of CO<sub>2</sub> gas content in flue gas streams. Key is the specially formulated **ASCOSORB** extraction solvent which provides the CO<sub>2</sub> Stack Gas Recovery Plant with reduced OPEX as a result of its CO<sub>2</sub> gas extraction and loading capability compared to other competitive solvent mixtures. This technology not only offers the end user a reliable CO<sub>2</sub> source but as well considered by many a green approach to the overall concept to CO<sub>2</sub> gas recovery. Combined with the specially formulated **ASCOSORB** Solvent, the ASCO CO<sub>2</sub> Stack Gas Recovery System utilizes stainless steel process towers and pumps to ensure long and effective equipment life and reliable performance for years to come.

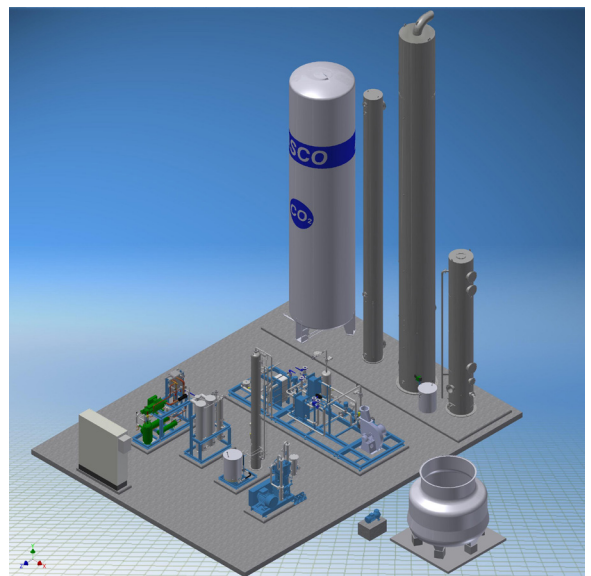



## ASCO CO<sub>2</sub> Stack Gas Recovery Systems: Features

Feature	Benefit
Stainless steel construction	Long plant longevity
Low energy consumption	Low OPEX
Integrated amine recovery	Contributing to the already reduced OPEX
High CO <sub>2</sub> extraction	Low carbon foot print
Retrofits easily to existing CO <sub>2</sub> production plants	Modernize your existing plant by eliminating fuel burning and saving up to 70 % production costs.
Flexible layout	Compact, modular component design means fast and easy installation and provides an economical use of available space, covering a variety of different layouts.
Inline scrubber water recirculation and treatment system	Designed to handle all the process scrubbing water, this system recycles, neutralises and sheds the process heat from the water all in one circuit. This significantly reduces the volume of water discharged to drain, providing an economical and environmentally friendly water system.
Process towers location	Option of indoor or outdoor installation of all process towers allows flexibility of layout in a variety of different situations. Outdoor location also reduces the required weather protection for the system.
Oilfree CO <sub>2</sub> compressor	Specially designed for use with CO <sub>2</sub> gas, the oilfree compressor means there is no possibility of CO <sub>2</sub> contamination with oil.
High pressure stainless steel purifier	Longer residence time provides ultra-efficient NO <sub>x</sub> and H <sub>2</sub> S removal.
Carbon filter	A high capacity carbon filtration column is installed in the CO <sub>2</sub> gas inlet line to the liquefier, to provide further assurance of pure and odour-free CO <sub>2</sub> .
Centralized control panel	Automatic plant operation and visual display (HMI) provide one touch read-outs of process data from a centralized position.



CO<sub>2</sub> 2-stage-compressor



Outdoor towers



High pressure purifier

# ASCO CO<sub>2</sub> Stack Gas Recovery Systems

## General process description

Flue gas from boiler exhausts (be it existing, new or even power generators) contain combustion products like CO<sub>2</sub>, water vapor, N<sub>2</sub>, O<sub>2</sub>, CO, and possibly SO<sub>2</sub> depending on the fuel being used. This flue gas, under the **ASCOSORB** process, is first cooled and treated for SO<sub>2</sub> effectively rendering a flue gas to a proper operating temperature and reaching an acceptable level of SO<sub>2</sub> prior to entering the **ASCOSORB** process of CO<sub>2</sub> Gas extraction.

Once cooled and treated the flue gas enters the CO<sub>2</sub> stack gas recovery system for extraction of CO<sub>2</sub> gas from the flue gas, using specially formulated **ASCOSORB** absorption solvent combined with process towers and packing for best overall efficiency. These towers include the CO<sub>2</sub> gas absorber and CO<sub>2</sub> stripper. It's the combination of the specially formulated **ASCOSORB** solvent and the optimized packing technology that gives the extraction process the efficiency to nearly extract all the CO<sub>2</sub> present in the flue gas as well as be resistant to any level of O<sub>2</sub> present in the source stream. Once absorbed, the CO<sub>2</sub> gas is carried away within the special **ASCOSORB** solvent, and remaining products of combustion are vented off the top of the absorber tower. The solvent, enriched with CO<sub>2</sub>, is passed to the stripper tower which uses reboiled lean solvent combined with tower and structured packing material to liberate the CO<sub>2</sub> gas from the enriched solvent stream. The exit CO<sub>2</sub> gas from the stripper is at a controlled temperature and pressure ready for further processing.

CO<sub>2</sub> gas processing from the **ASCO** CO<sub>2</sub> Stack Gas Recovery System is completed with the efficient and high quality supply of **ASCO** compression, purification, drying and liquefaction equipment typical of supply with our production and by-product recovery plants. This ensures the liquid CO<sub>2</sub> produced from the total **ASCO** CO<sub>2</sub> Stack Gas Recovery Plant exceeds the parameters set forth by many customers and industry standards.



Process unit



Liquefaction unit

## Capacities

Available standard capacities: 500 to 2'000 kg/h (1'100 to 4'400 lb/h)

Individually engineered plants available for capacities up to 11'000 kg/h (24'250 lb/h)

## Utility Consumptions

**Thermal energy consumption: only approx. 1.3 mW<sub>th</sub>/MT produced CO<sub>2</sub>**

Complete information of utility consumptions provided with each **ASCO** proposal for a CO<sub>2</sub> Stack Gas Recovery System.

# ASCO CO<sub>2</sub> Stack Gas Recovery Systems

Standard Layout Proposal dimensions in mm (in)				
Capacity	A	B	C	D
500 kg/h (1'100 lb/h)	20'000 (787)	17'000 (670)	12'000 (472)	6'000 (236)
1'000 kg/h (2'200 lb/h)	21'300 (838)	18'300 (720)	14'150 (557)	6'000 (236)
1'500 kg/h (3'300 lb/h)	30'000 (1'181)	25'000 (984)	17'500 (689)	6'500 (256)
2'000 kg/h (4'400 lb/h)	34'500 (1'358)	28'500 (1'122)	18'000 (708)	7'000 (275)

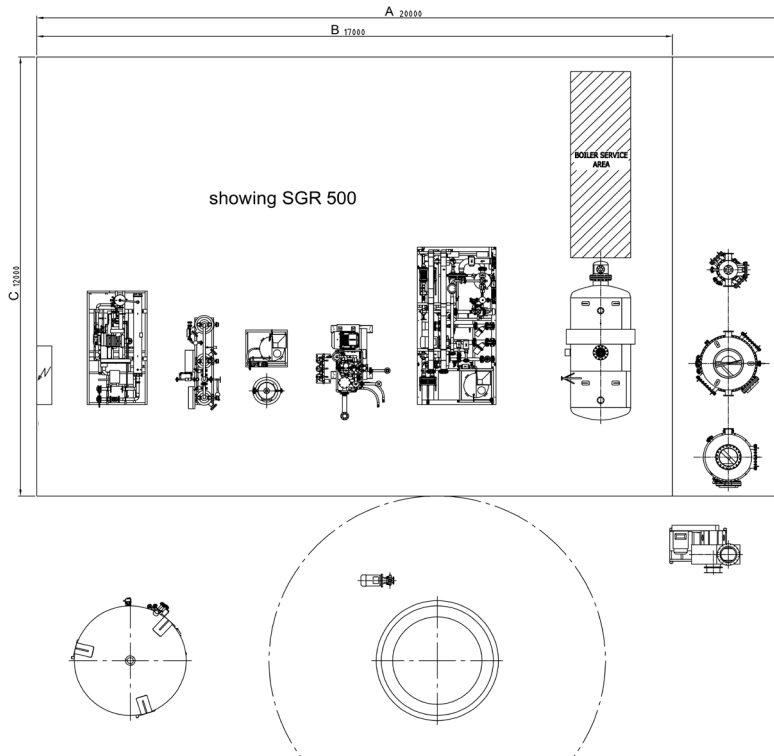
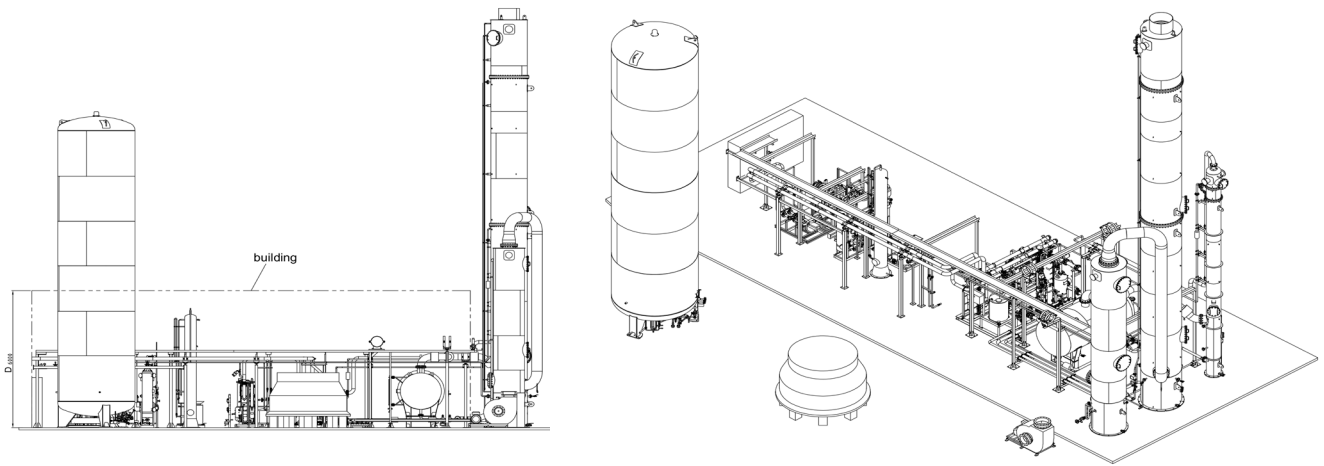

Subject to technical changes / improvements

# CO<sub>2</sub> Recovery

## ASCO CO<sub>2</sub> By-Product Recovery Systems (BPR)



**ASCO's innovative CO<sub>2</sub> Gas Recovery Technology turns your vented by-product gas into profitable CO<sub>2</sub>.**

Be it for an alcoholic fermentation process (e.g. breweries, ethanol operations, distilleries or wineries), other industrial sources (e.g. ammonia production or hydrogen reforming) or natural sources, **ASCO** will find your individual CO<sub>2</sub> recovery solution.



**ASCO's By-Product CO<sub>2</sub> Gas Recovery System** can make this opportunity a reality to those interested in developing a business case and realizing the potential rewards of recovering CO<sub>2</sub> gas from these sources. Our systems, manufactured of the highest quality in materials and workmanship, offers extremely low operating costs placing the least OPEX against CAPEX providing a far greater return on investment.

### ASCO By-Product Recovery Systems: Key features

**ASCO** By-Product CO<sub>2</sub> Gas Recovery Systems enhance the overall concept for your recovery opportunity considering the following **key benefits**:

- **ASCO** CO<sub>2</sub> Gas Recovery Systems can be applicable to a variety of sources;
- Our advanced technology is strategically positioned offering lowest cost production/ton;
- The environmentally friendly technology – gas scrubbing, purifying, drying -eliminates chemical treatment and handling and offers overall reduced effluent and cost savings/ton;
- Totally automatic process – plant operations and liquid CO<sub>2</sub> tank farm management;
- The **ASCO** CO<sub>2</sub> Gas Recovery System achieves liquid CO<sub>2</sub> purity of 99.998 % from an inlet CO<sub>2</sub> gas source purity as low as 98.5%;
- For CO<sub>2</sub> sources with a purity of 95 % or higher, we offer recovery systems on request.
- Final liquid CO<sub>2</sub> quality exceeds international food and beverage standards.
- **Capacities available from 500 to 6'500 kg/h (1'100 to 14'330 lb/h) (other capacities on request)**

# ASCO CO<sub>2</sub> By-Product Recovery Systems

## General process description

	Alcohol sources	Industrial sources	Natural sources
From a raw gas source ↓ to 99.998% pure CO <sub>2</sub> .	CO <sub>2</sub> gas is generated as a by-product of the <b>alcoholic fermentation process</b> (e.g. breweries, ethanol operations, distilleries, wineries). This then is collectively reclaimed from the fermentation area through adequately sized collection pipe lines for common feed to the <b>ASCO CO<sub>2</sub> Gas Recovery System</b> . The gas at this point will be at low pressure and combined purity of >98.5%.	CO <sub>2</sub> gas can be generated as a by-product of <b>various industrial sources</b> (e.g. ammonia production or hydrogen reforming) and as such can be reclaimed for feed to the <b>ASCO CO<sub>2</sub> Gas Recovery System</b> .	CO <sub>2</sub> gas can be generated from <b>natural origin</b> (e.g. from natural underground wells). These source gases then can be reclaimed for feed to the <b>ASCO CO<sub>2</sub> Gas Recovery System</b> .
	The recovery plant compresses CO <sub>2</sub> gas, elevating the pressure to approximately 18 barg for CO <sub>2</sub> gas processing that being: washing, purifying, drying and CO <sub>2</sub> gas condensing. Our selection of specially designed compressors offer the best in energy utilization, dry gas compression and ease of maintenance.		
	Once compressed, CO <sub>2</sub> gas is treated for removal of impurities typical of these sources by high pressure high efficiency CO <sub>2</sub> gas washing (scrubbing) providing a CO <sub>2</sub> purity of min 99.9%.		
	<b>ASCO's</b> system design further enhances the gas quality by proper CO <sub>2</sub> gas purifying. This is accomplished by an activated desiccant bed for gas drying to a dew point of minus 40 °C at pressure (-62 °C at atmospheric pressure) followed by carbon polish filter, again subject to raw gas and process conditions. Once the operation is completed, the final gas will be odour free, colour free and taste free, preparing for the last stages of purification.		
	As a means of final purification the CO <sub>2</sub> gas is condensed (separation of non-condensable gases). CO <sub>2</sub> gas condensing is accomplished by use of an independent refrigeration system that liquefies CO <sub>2</sub> gas at approximately 18 barg and minus 24 °C. The non-condensable gases present in the CO <sub>2</sub> gas are separated and purged from the system automatically and reused for regeneration gas within the plant.		
Liquid CO <sub>2</sub> leaving the CO <sub>2</sub> condenser flows by gravity to a liquid CO <sub>2</sub> purification system to achieve a final liquid CO <sub>2</sub> purity of 99.998%. Thereafter, high quality liquid CO <sub>2</sub> is pumped to a liquid CO <sub>2</sub> storage tank for handling the liquid CO <sub>2</sub> such as bulk supply, cylinder supply, dry ice supply for chilling or dry ice supply for blast cleaning.			

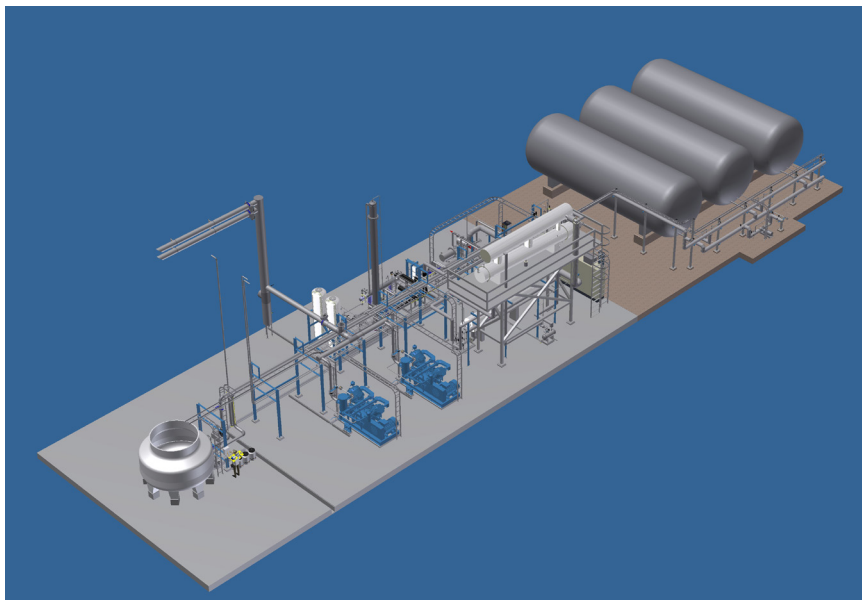

# CO<sub>2</sub> Gas Revert Recovery

## ASCO CO<sub>2</sub> Gas Revert Recovery Systems (RRSi)



**ASCO** CO<sub>2</sub> Gas Revert Recovery Systems are engineered to efficiently recover the revert CO<sub>2</sub> gas from **ASCO** Dry Ice Pellet and Block Machines which normally direct the revert (flash) gas to the atmosphere.

### Advantages of CO<sub>2</sub> Revert Recovery Systems:

- Reducing dry ice production costs up to 50 % by recovering the normally “lost” CO<sub>2</sub> gas due to vent typical of dry ice manufacturing
- Automatic (PLC) operation
- Heavy duty, compact and efficient design
- Packaged, prepiped and prewired for timely installation

When dry ice is produced the conversion rate from liquid CO<sub>2</sub> to dry ice is approx. 40 - 45 %. This means 55 - 60 % is lost to the atmosphere. This conversation rate is a physical fact and therefore, unfortunately, not to change. **With the ASCO CO<sub>2</sub> Revert Recovery System (RRS), however, most of the CO<sub>2</sub> can be recovered** which leads to a **final conversion rate of approx. 90 - 95 %.**

As models of **ASCO's i-Series**, the CO<sub>2</sub> Gas Revert Recovery Systems RRSi are equipped with state-of-the-art remote control devices and thus is ready for a wide range of services in the areas of **Remote Access, Remote Data, Remote Management.**

### Specifications

Model	RRS 320i	RRS 540i	RRS 1020i
Revert CO <sub>2</sub> gas (lb/h)	320kg/h (705)	540kg/h (1190)	1020kg/h (2249)
Absorbed power in kW (HP) approx.	69 (92.5)	106 (142)	184 (247)
Installed power in kW (HP)	88 (118)	144 (193)	247 (331)
Est. cooling water flow rate requirement m <sup>3</sup> /h (ft <sup>3</sup> /h)	15.1 (533)	24.1 (851)	40.2 (1420)
Weight in kg (lb) approx.	8500 (18739)	8500 (18739)	
Dimensions LxWxH in mm (ft)	7200 x 2000 x 5900 (23.62 x 6.56 x 19.36)	7200 x 2000 x 5900 (23.62 x 6.56 x 19.36)	
Voltage:	400 VAC ± 5 % / 3ph + PE / 50 Hz		
Instrument control air:	< 2m <sup>3</sup> /h (< 70.3 ft <sup>3</sup> /h), 6 bar g (87 psi), dew point -40 °C (F), oil free		
Sound level:	approx. 86 dB		

Exact specification according to technical offer details.

## ASCO CO<sub>2</sub> Gas Revert Recovery Systems: Special features

CO <sub>2</sub> buffer balloon	Specially designed, made of foodgrade acceptable material, to provide a constant back pressure to the dry ice machine as well as provide constant supply conditions of CO <sub>2</sub> flow to the gas compressor. Local conditions may require reheating of the CO <sub>2</sub> revert gas which can be supplied as required for each application.
CO <sub>2</sub> compressor	A water-cooled, dry-running, non-lubricated and oil-free 2-stage CO <sub>2</sub> piston compressor, with separate cooling for each stage, compresses the recovered gas down to 18-20 barg.
CO <sub>2</sub> liquefier	Liquefies the compressed CO <sub>2</sub> gas through a standard refrigeration loop. The re-liquefied CO <sub>2</sub> is then returned to the liquid CO <sub>2</sub> storage tank for reuse in dry ice production.
Control system	A central control system automatically controls the entire process and houses the electric motor distribution, starting, operator interface and PLC control system.

### How the ASCO CO<sub>2</sub> Revert Recovery System interconnects with ASCO Dry Ice Equipment:

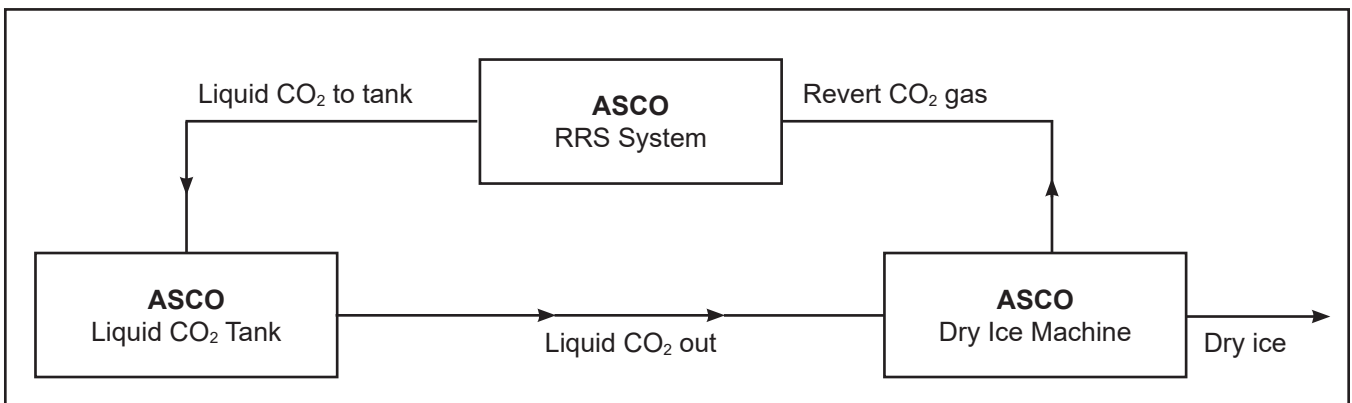

## ASCO CO<sub>2</sub> Gas Revert Recovery System RRS: Sample views

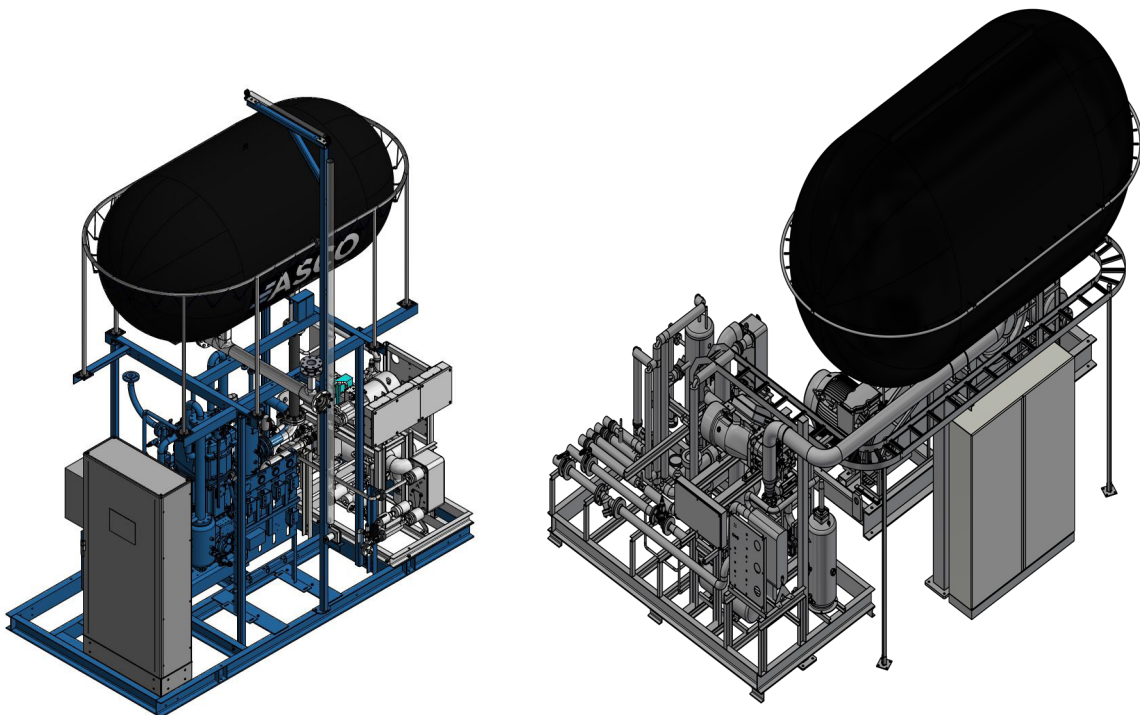

Example RRS 320i

Example RRS 1020i

Pos. 001

## ASCO CO<sub>2</sub> Gas Revert Recovery System RRS 320i (water-cooled)

part no. 901504

To recover up to **320 kg/h (705 lb/h)** of revert CO<sub>2</sub> gas from the production of dry ice.

### Scope of supply:

- CO<sub>2</sub> gas balloon buffer storage (mounted remotely or directly on the RRS)
- CO<sub>2</sub> compressor, dry running 2 stage, water cooled
- CO<sub>2</sub> liquefier, refrigerant, water cooled with stainless steel CO<sub>2</sub> condenser
- Allowance for insulated outlet CO<sub>2</sub> liquid line from the RRS to the liquid CO<sub>2</sub> storage tank (up to 10 m) (33 ft)
- Central control panel with operator interface
- Modularized design is prepiped, prewired and precabled for fast installation
- ASCO i-Series connection for remote maintenance and diagnostics

The RRS 320i should be positioned as close as possible to the dry ice production (max. 8m distance and max. 4 arches).

**Utility specifications according to technical offer details -without options and accessories**



Example picture

Pos. 002

## ASCO CO<sub>2</sub> Gas Revert Recovery System RRS 540i (water-cooled)

part no. 901505

To recover up to **540 kg/h (1190 lb/h)** of revert CO<sub>2</sub> gas from the production of dry ice.

### Scope of supply:

- CO<sub>2</sub> gas balloon buffer storage (mounted remotely or directly on the RRS)
- CO<sub>2</sub> compressor, dry running 2 stage, water cooled
- CO<sub>2</sub> liquefier, refrigerant, water cooled with stainless steel CO<sub>2</sub> condenser
- Allowance for insulated outlet CO<sub>2</sub> liquid line from the RRS to the liquid CO<sub>2</sub> storage tank (up to 10 m 33 ft)
- Central control panel with operator interface
- Modularized design is prepiped, prewired and precabled for fast installation
- ASCO i-Series connection for remote maintenance and diagnostics

The RRS 540i should be positioned as close as possible to the dry ice production (max. 8m distance and max. 4 arches).

**Utility specifications according to technical offer details -without options and accessories**



Example picture



## ASCO CO<sub>2</sub> Gas Revert Recovery System RRS: Available standard capacities

Pos. 003

### ASCO CO<sub>2</sub> Gas Revert Recovery System RRS1020i (water-cooled)

part no. 901506

To recover up to **1020 kg/h (2'249 lb/h)** of revert CO<sub>2</sub> gas from the production of dry ice.

#### Scope of supply:

- CO<sub>2</sub> gas balloon buffer storage (mounted remotely or directly on the RRS)
- CO<sub>2</sub> compressor, dry running 2 stage, water cooled
- CO<sub>2</sub> liquefier, refrigerant, water cooled with stainless steel CO<sub>2</sub> condenser
- Allowance for insulated outlet CO<sub>2</sub> liquid line from the RRS to the liquid CO<sub>2</sub> storage tank (up to 10 m) (32.8 ft)
- Central control centre and control panel with operator interface
- Modularized design is prepiped, prewired and precabled for fast installation
- ASCO i-Series connection for remote maintenance and diagnostics

The RRS 1020i should be positioned as close as possible to the dry ice production (max. 8m distance and max. 4 arches).

**Utility specifications according to technical offer details -without options and accessories**



Example picture

## ASCO CO<sub>2</sub> Gas Revert Recovery System RRS: Options

### Remote PanelView

part no. 4070295

The ASCO Remote PanelView makes it possible to monitor the system at a second location up to 95m (311 ft) away.

### Spare parts package

The spare parts package includes parts for 2 years of operation. Designed according to the system size:

**ASCO CO<sub>2</sub> Gas Revert Recovery System RRS 320i**

part no. 4070292

**ASCO CO<sub>2</sub> Gas Revert Recovery System RRS 540i**

part no. 4070293

**ASCO CO<sub>2</sub> Gas Revert Recovery System RRS 1020i**

part no. 4070294

### Water Cooling System (Induced Draft Axial Fan Counterflow)

High performance cooling water system with a corrosion resistant cooling tower, complete with cooling water pump, associated valves and accessories for the cooled water needed.

Designed according to the system size:

<b>ASCO CO<sub>2</sub> Gas Revert Recovery System RRS 320i</b>	<b>part no. 4070296</b>
<b>ASCO CO<sub>2</sub> Gas Revert Recovery System RRS 540i</b>	<b>part no. 4070297</b>
<b>ASCO CO<sub>2</sub> Gas Revert Recovery System RRS 1020i</b>	<b>part no. 4070298</b>

### Water Cooling System (Closed Circuit)

High performance closed circuit cooling water systems are used as an alternative to open circuit cooling with heat exchangers in those cases where the cooling liquid for the user's equipment needs to keep its chemical and physical properties constant over time and not be contaminated by external elements. Generally filled with water or water with glycol.

Designed according to the system size:

<b>ASCO CO<sub>2</sub> Gas Revert Recovery System RRS 320i</b>	<b>part no. 4070299</b>
<b>ASCO CO<sub>2</sub> Gas Revert Recovery System RRS 540i</b>	<b>part no. 4070300</b>
<b>ASCO CO<sub>2</sub> Gas Revert Recovery System RRS 1020i</b>	<b>part no. 4070301</b>

### Water Cooling System (Adiabatic Cooler)

Ideal for saving water at a high efficiency at the same time. A high performance cooled water system with a corrosion resistant cooling tower, complete with cooling water pump, associated valves and accessories.

Designed according to the system size:

<b>ASCO CO<sub>2</sub> Gas Revert Recovery System RRS 320i</b>	<b>part no. 4070302</b>
<b>ASCO CO<sub>2</sub> Gas Revert Recovery System RRS 540i</b>	<b>part no. 4070303</b>
<b>ASCO CO<sub>2</sub> Gas Revert Recovery System RRS 1020i</b>	<b>part no. 4070304</b>

# ASCO - the complete CO<sub>2</sub> Solution

Complete your ASCO CO<sub>2</sub> Production- / Recovery Plant with some of our many accessories

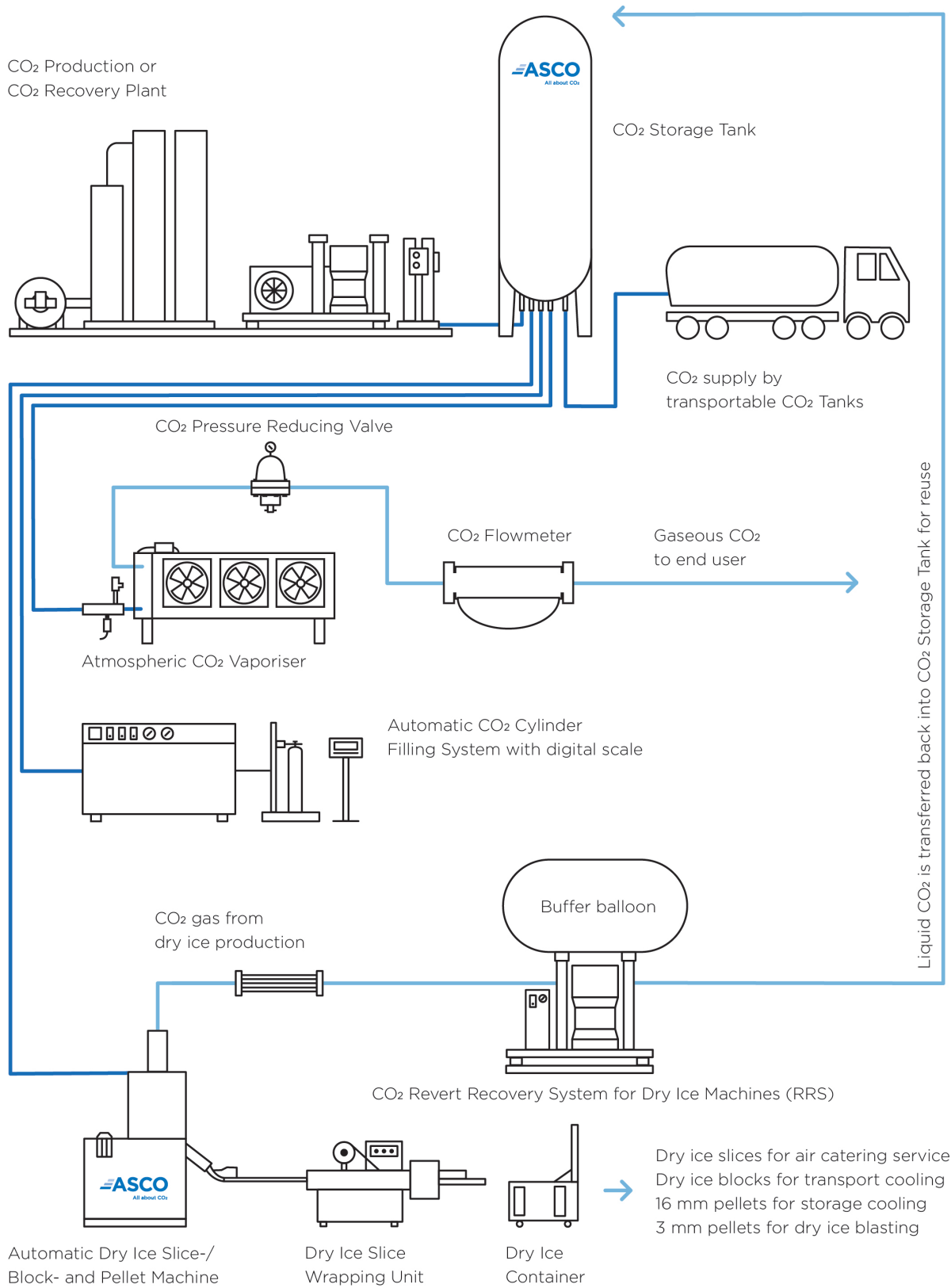

All photos and drawings are used for marketing purposes only.

# CO<sub>2</sub> Storage

## ASCO CO<sub>2</sub> Storage Tanks Vacuum Insulated



ASCO CO<sub>2</sub> Storage Tanks include a high quality perlite vacuum insulation and are supplied complete with all pipework, valves, safety devices, liquid level indicator, pressure gauge, automatic pressure build up and pressure reducing systems allowing fast and easy installation on site.

The inner tank is made of stainless steel or carbon steel. The outer vessel has a durable protective coating to guard against corrosion.

All interconnecting pipework is made of stainless steel. Special connections are included to allow easy installation of any ancillary equipment such as vaporisers, cylinder filling systems, transfer pumps and dry ice machines etc.

- compact
- simple and safe to operate
- easily installed

### Horizontal and vertical tanks

ASCO Storage Tanks are available as horizontal or vertical versions.

### Cryogenic gases

Vertical ASCO Storage Tanks can also be configured for other liquefied cryogenic gases (N<sub>2</sub>, O<sub>2</sub>, Ar).

### Specifications

<b>Inner vessel:</b>	Stainless or carbon steel	<b>Piping:</b>	Stainless steel
<b>Outer vessel:</b>	Carbon steel	<b>Level indication:</b>	Differential pressure measuring device (outlet 4 - 20 mA)
<b>Max. working pressure (CO<sub>2</sub> Tanks):</b>	22 bar (319 psi)	<b>Filling connections:</b>	According to ASCO flow diagram
<b>Insulation:</b>	High quality vacuum perlite	<b>Approval:</b>	PED 2014/68/EU or AD2000 and other international codes

ASCO reserves the right to modify all specifications without prior notice.

## ASCO CO<sub>2</sub> Storage Tanks: Special features

### Advantages of ASCO vacuum insulated CO<sub>2</sub> Storage Tanks:

- Low maintenance
- Installation is straightforward
- All pipework on vacuum insulated tanks are made of stainless steel
- Vacuum insulated tanks include automatic pressure build up and pressure reducing systems
- Special connections are included to allow easy installation of vaporisers, cylinder filling systems, transfer pumps and dry ice machines
- Tanks can be ordered with different pipework arrangement for other liquefied cryogenic gases (Nitrogen, Oxygen, Argon)

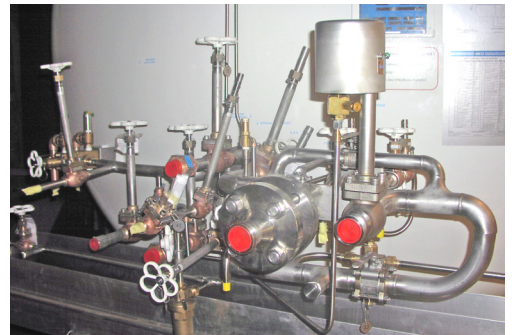
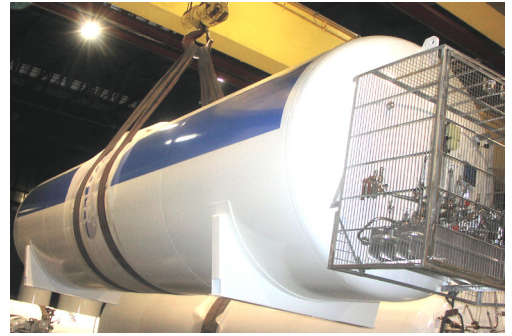

### Easy Handling and easy Installation on Site:

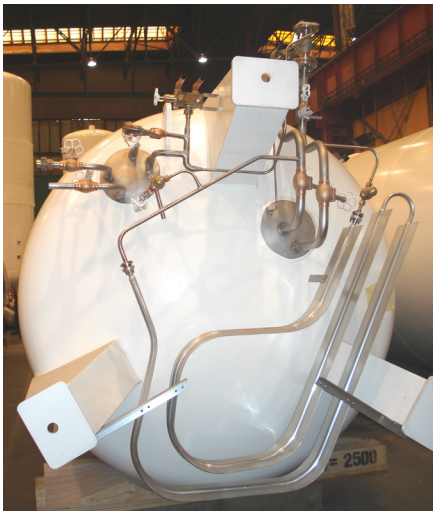

**ASCO's** vacuum insulated Storage Tanks are designed for easy handling and installation on site.

The stainless steel pipework offers the possibility to connect the following equipment to the tank:

- CO<sub>2</sub> cylinder filling systems
- Atmospheric CO<sub>2</sub> vaporisers
- Dry ice pelletizers / block machines
- CO<sub>2</sub> production plants
- CO<sub>2</sub> recovery systems
- CO<sub>2</sub> transfer pumps

## Typical ASCO CO<sub>2</sub> Pipework: Arrangement

All pipework and valves are made of stainless steel. Automatic pressure build up and pressure reducing systems are standardly included to provide stable tank pressure condition.

### Optional:

If a tank is used for storing CO<sub>2</sub> without regular withdrawal, a refrigeration unit can be supplied.

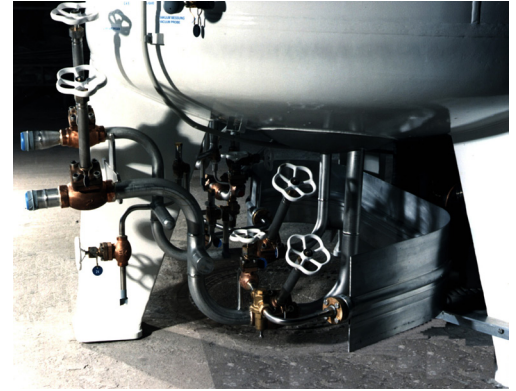
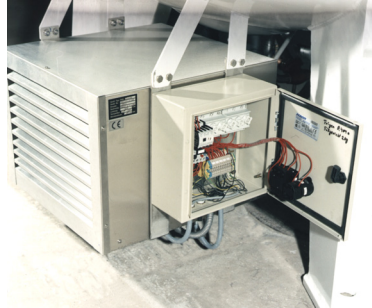

## Pressure and Level Indicator:



### Differential pressure indicator Media 7 for liquid level indication

- Microprocessor-controlled transmitter with interface for configuration and programming on site
- Digital display (LCD) for temperatures down to  $-40^{\circ}\text{C}$  with 100% bar graph as well as alarm and warning markers
- Two-wire connection for 4 - 20 mA signal

# Vertical vacuum insulated ASCO CO<sub>2</sub> Tanks

## Flow diagram No. 700

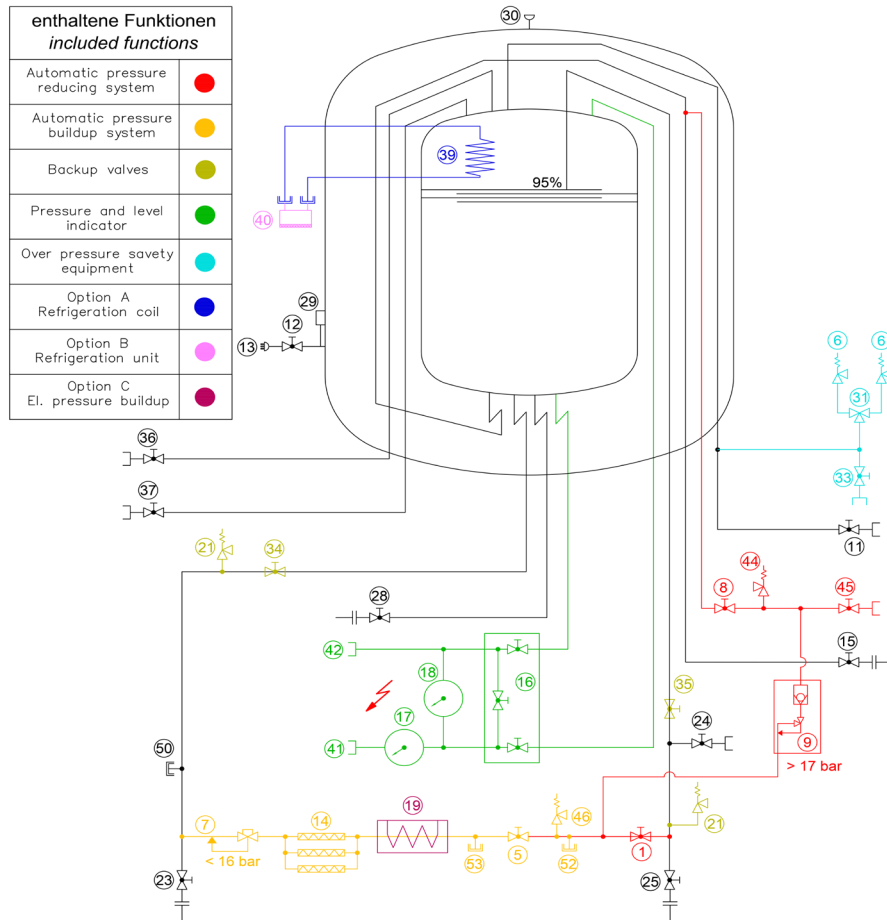

All pipework is aligned inside the tank and the connections are at the bottom of the tank.

- |    |   |    |                                     |
|----|---|----|-------------------------------------|
| 1  | Shut-off valve pressure reducing system | 28 | Valve for liquid withdrawal         |
| 5  | Shut-off valve pressure building system | 29 | Evacuation connection outer casting |
| 6  | Main safety valve                       | 30 | Bursting disk for outer tank        |
| 7  | Pressure building regulator             | 31 | Change over valve                   |
| 8  | Shut-off valve pressure reducing system | 33 | Vent valve                          |
| 9  | Pressure reducing regulator             | 34 | Back-up valve liquid line           |
| 11 | Vent valve                              | 35 | Back-up valve gas line              |
| 12 | Valve for vacuum probe                  | 36 | Valve for gas withdrawal            |
| 13 | Vacuum probe                            | 37 | Valve for gas withdrawal            |
| 14 | Vaporiser for pressure building system  | 39 | Refrigeration coil                  |
| 15 | Valve for liquid withdrawal (vaporiser) | 40 | Refrigeration unit                  |
| 16 | Thee valve manifold                     | 41 | Connection for pressure measuring   |
| 17 | Pressure gauge                          | 42 | Connection for pressure measuring   |
| 18 | Liquid level indicator                  | 44 | Line safety valve                   |
| 19 | Electrical pressure building heater     | 45 | Valve for plant                     |
| 21 | Line safety valve                       | 46 | Line safety valve                   |
| 23 | Valve for liquid fill connection        | 50 | Connection for liquid withdrawal    |
| 24 | Overflow valve                          | 52 | Connection for liquid withdrawal    |
| 25 | Valve for gas fill connection           | 53 | Connection for liquid withdrawal    |

# Horizontal vacuum insulated ASCO CO<sub>2</sub> Tanks

## Flow diagram No. 750

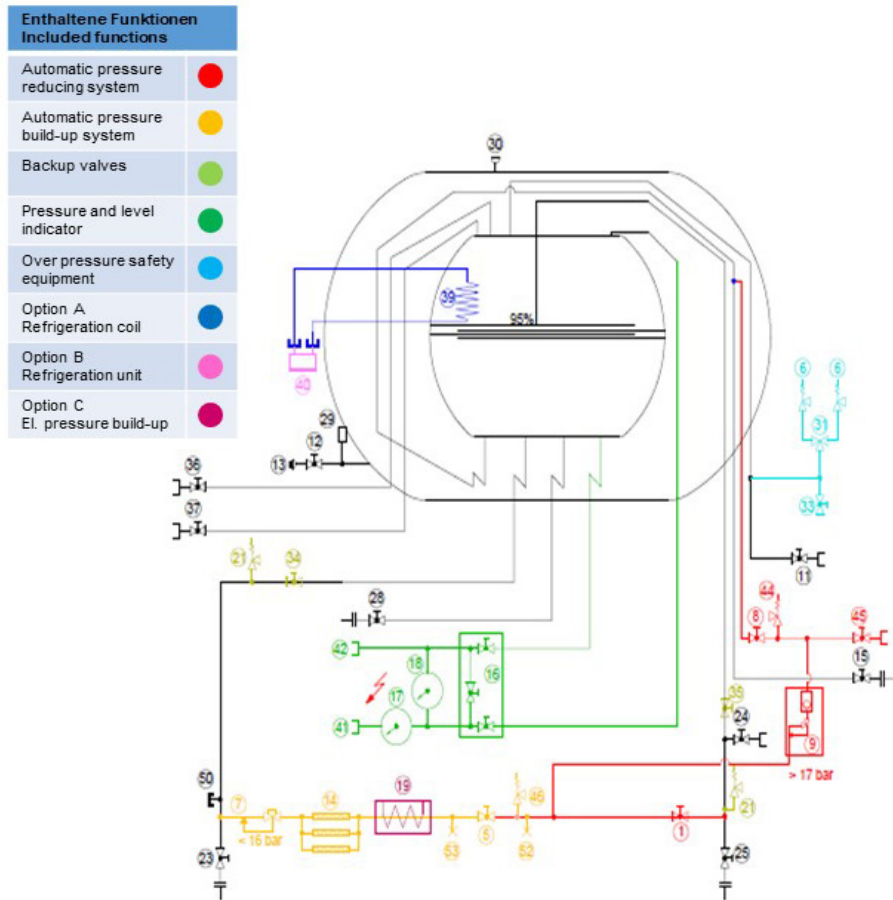

All pipework is aligned inside the tank and the connections are at the bottom of the tank.

- |    |   |    |                                     |
|----|---|----|-------------------------------------|
| 1  | Shut-off valve pressure reducing system | 28 | Valve for liquid withdrawal         |
| 5  | Shut-off valve pressure build-up system | 29 | Evacuation connection outer casting |
| 6  | Main safety valve                       | 30 | Bursting disk for outer tank        |
| 7  | Pressure build-up regulator             | 31 | Change over valve                   |
| 8  | Shut-off valve pressure reducing system | 33 | Vent valve                          |
| 9  | Pressure reducing regulator             | 34 | Back-up valve liquid line           |
| 11 | Vent valve                              | 35 | Back-up valve gas line              |
| 12 | Valve for vacuum probe                  | 36 | Valve for gas withdrawal            |
| 13 | Vacuum probe                            | 37 | Valve for gas withdrawal            |
| 14 | Vaporiser for pressure build-up system  | 39 | Refrigeration coil                  |
| 15 | Valve for liquid withdrawal (vaporiser) | 40 | Refrigeration unit                  |
| 16 | Thee valve manifold                     | 41 | Connection for pressure measuring   |
| 17 | Pressure gauge                          | 42 | Connection for pressure measuring   |
| 18 | Liquid level indicator                  | 44 | Line safety valve                   |
| 19 | Electrical pressure build-up heater     | 45 | Valve for plant                     |
| 21 | Line safety valve                       | 46 | Line safety valve                   |
| 23 | Valve for liquid fill connection        | 50 | Connection for liquid withdrawal    |
| 24 | Overflow valve                          | 52 | Connection for liquid withdrawal    |
| 25 | Valve for gas fill connection           | 53 | Connection for liquid withdrawal    |



## Vertical vacuum insulated ASCO Storage Tanks: Available standard capacities

Pos. 001

### 6.4 t (14'110 lb) / 6'400 l vertical, vacuum insulated storage tank

Tank to be supplied complete with all pipework in stainless steel, valves, safety devices, differential pressure liquid level indicator, vacuum insulated

- diameter: 1'600 mm (63 in) / height: 7'500 mm (295 in)
- including registration by German TÜV according to PED 2014/68/EU and AD2000 (also for CH)

#### CO<sub>2</sub>: (available options please see flow diagram no. 700)

- maximum filling weight of **6'100 kg (13'448 lb)**
- safety valve setting 22 bar (319 psi)
- inner vessel made of stainless steel

part no.

CO<sub>2</sub> **900800**



Pos. 002

### 11.0 t (24'251 lb) / 11'000 l vertical, vacuum insulated storage tank

Tank to be supplied complete with all pipework in stainless steel, valves, safety devices, differential pressure liquid level indicator, vacuum insulated.

- diameter: 2'200 mm (87 in) / height: 6'400 mm (252 in)
- including registration by German TÜV according to PED 2014/68/EU and AD2000 (also for CH)

#### CO<sub>2</sub>: (available options please see flow diagram no. 700)

- maximum filling weight of **10'540 kg (23'237 lb)**
- safety valve setting 22 bar (319 psi)
- inner vessel standardly made of carbon steel, also available in stainless steel

#### LIN, LOX, LAR:

- maximum net capacity of **10'450 litres (2'761 gal)**
- MAWP 18.5 bar (268 psi)
- inner vessel made of stainless steel

part no.

CO<sub>2</sub> **900737**  
LIN, LOX, LAR **4046463**



Pos. 003

### 17.0 t (37'479 lb) / 17'000 l vertical, vacuum insulated storage tank

Tank to be supplied complete with all pipework in stainless steel, valves, safety devices, differential pressure liquid level indicator, vacuum insulated.

- diameter: 2'200 mm (87 in) / height: 8'950 mm (352 in)
- including registration by German TÜV according to PED 2014/68/EU and AD2000 (also for CH)

#### CO<sub>2</sub>: (available options please see flow diagram no. 700)

- maximum filling weight of **16'290 kg (35'913 lb)**
- safety valve setting 22 bar (319 psi)
- inner vessel standardly made of carbon steel, also available in stainless steel

#### LIN, LOX, LAR:

- maximum net capacity of **16'150 litres (4'266 gal)**
- MAWP 18.5 bar (268 psi)
- inner vessel made of stainless steel

part no.

CO<sub>2</sub> **900741**  
LIN, LOX, LAR **4046464**



## Vertical vacuum insulated ASCO Storage Tanks: Available standard capacities

Pos. 004

### 20.0 t (44'093 lb) / 20'000 l vertical, vacuum insulated storage tank

Tank to be supplied complete with all pipework in stainless steel, valves, safety devices, differential pressure liquid level indicator, vacuum insulated.

- diameter: 2'200 mm (87 in) / height: 10'250 mm (404 in)
- including registration by German TÜV according to PED 2014/68/EU and AD2000 (also for CH)

#### CO<sub>2</sub>: (available options please see flow diagram no. 700)

- maximum filling weight of **19'160 kg (42'241 lb)**
- safety valve setting 22 bar (319 psi)
- inner vessel standardly made of carbon steel, also available in stainless steel

#### LIN, LOX, LAR:

- maximum net capacity of **19'000 litres (5'019 gal)**
- MAWP 18.5 bar (268 psi)
- inner vessel made of stainless steel

part no.

CO<sub>2</sub>                      900743  
LIN, LOX, LAR        4046465



Pos. 005

### 23.0 t (50'706 lb) / 23'000 l vertical, vacuum insulated storage tank

Only available for CO<sub>2</sub> storage

Tank to be supplied complete with all pipework in stainless steel, valves, safety devices, differential pressure liquid level indicator, vacuum insulated.

- diameter: 2'200 mm (87 in) / height: 11'600 mm (457 in)
- including registration by German TÜV according to PED 2014/68/EU and AD2000 (also for CH)

#### CO<sub>2</sub>: (available options please see flow diagram no. 700)

- maximum filling weight of **22'110 kg (48'744 lb)**
- safety valve setting 22 bar (319 psi)
- inner vessel standardly made of carbon steel, also available in stainless steel

part no.

CO<sub>2</sub>                      900744



Pos. 006

### 28.0 t (61'729 lb) / 28'000 l vertical, vacuum insulated storage tank

Tank to be supplied complete with all pipework in stainless steel, valves, safety devices, differential pressure liquid level indicator, vacuum insulated.

- diameter: 2'500 mm (98 in) / height: 10'350 mm (407 in)
- including registration by German TÜV according to PED 2014/68/EU and AD2000 (also for CH)

#### CO<sub>2</sub>: (available options please see flow diagram no. 700)

- maximum filling weight of **26'820 kg (59'128 lb)**
- safety valve setting 22 bar (319 psi)
- inner vessel standardly made of carbon steel, also available in stainless steel

#### LIN, LOX, LAR:

- maximum net capacity of **26'600 litres (7'027 gal)**
- MAWP 18.5 bar (268 psi)
- inner vessel made of stainless steel

part no.

CO<sub>2</sub>                      900745  
LIN, LOX, LAR        4046466



# Vertical vacuum insulated ASCO Storage Tanks: Available standard capacities

Pos. 007

## 32.0 t (70'548 lb) / 32'300 l vertical, vacuum insulated storage tank

Tank to be supplied complete with all pipework in stainless steel, valves, safety devices, differential pressure liquid level indicator, vacuum insulated.

- diameter: 2'500 mm (98 in) / height: 11'600 mm (457 in)
- including registration by German TÜV according to PED 2014/68/EU and AD2000 (also for CH)

### CO<sub>2</sub>: (available options please see flow diagram no. 700)

- maximum filling weight of **30'660 kg (67'594 lb)**
- safety valve setting 22 bar (319 psi)
- inner vessel standardly made of carbon steel, also available in stainless steel

### LIN, LOX, LAR:

- maximum net capacity of **30'690 litres (8'107 gal)**
- MAWP 18.5 bar (268 psi)
- inner vessel made of stainless steel

part no.

CO<sub>2</sub> 900746  
LIN, LOX, LAR 4046467



Pos. 008

## 37.0 t (81'571 lb) / 36'600 l vertical, vacuum insulated storage tank

Tank to be supplied complete with all pipework in stainless steel, valves, safety devices, differential pressure liquid level indicator, vacuum insulated.

- diameter: 2'500 mm (98 in) / height: 12'900 mm (508 in)
- including registration by German TÜV according to PED 2014/68/EU and AD2000 (also for CH)

### CO<sub>2</sub>: (available options please see flow diagram no. 700)

- maximum filling weight of **35'450 kg (78'154 lb)**
- safety valve setting 22 bar (319 psi)
- inner vessel standardly made of carbon steel, also available in stainless steel

### LIN, LOX, LAR:

- maximum net capacity of **34'770 litres (9'185 gal)**
- MAWP 18.5 bar (268 psi)
- inner vessel made of stainless steel

part no.

CO<sub>2</sub> 900747  
LIN, LOX, LAR 4046468



Pos. 009

## 41.0 t (90'390 lb) / 41'000 l vertical, vacuum insulated storage tank

Tank to be supplied complete with all pipework in stainless steel, valves, safety devices, differential pressure liquid level indicator, vacuum insulated.

- diameter: 2'500 mm (98 in) / height: 14'200 mm (557 in)
- including registration by German TÜV according to PED 2014/68/EU and AD2000 (also for CH)

### CO<sub>2</sub>: (available options please see flow diagram no. 700)

- maximum filling weight of **39'280 kg (86'598 lb)**
- safety valve setting 22 bar (319 psi)
- inner vessel standardly made of carbon steel, also available in stainless steel

### LIN, LOX, LAR:

- maximum net capacity of **38'950 litres (10'290 gal)**
- MAWP 18.5 bar (268 psi)
- inner vessel made of stainless steel

part no.

CO<sub>2</sub> 900748  
LIN, LOX, LAR 4046469



# Vertical vacuum insulated ASCO Storage Tanks: Available standard capacities

Pos. 010

## 50.0 t (110'231 lb) / 50'000 l vertical, vacuum insulated storage tank

Tank to be supplied complete with all pipework in stainless steel, valves, safety devices, differential pressure liquid level indicator, vacuum insulated.

- diameter: 3'000 mm (118 in) / height: 12'000 mm (472 in)
- including registration by German TÜV according to PED 2014/68/EU and AD2000 (also for CH)

### CO<sub>2</sub>: (available options please see flow diagram no. 700)

- maximum filling weight of **47'900 kg (105'601 lb)**
- safety valve setting 22 bar (319 psi)
- inner vessel standardly made of carbon steel, also available in stainless steel

### LIN, LOX, LAR:

- maximum net capacity of **47'500 litres (12'548 gal)**
- MAWP 18.5 bar (268 psi)
- inner vessel made of stainless steel

part no.

CO<sub>2</sub> 900750  
LIN, LOX, LAR 4046470



Pos. 011

## 60.0 t (132'277 lb) / 61'000 l vertical, vacuum insulated storage tank

Only available for LIN, LOX, LAR storage

Tank to be supplied complete with all pipework in stainless steel, valves, safety devices, differential pressure liquid level indicator, vacuum insulated.

- diameter: 3'000 mm (118 in) / height: 13'900 mm (472 in)
- including registration by German TÜV according to PED 2014/68/EU and AD2000 (also for CH)

### CO<sub>2</sub>: (available options please see flow diagram no. 700)

- maximum filling weight of **59'500 kg (131'175 lb)**
- safety valve setting 22 bar (319 psi)
- inner vessel standardly made of carbon steel, also available in stainless steel

### LIN, LOX, LAR:

- maximum net capacity of **57'950 litres (15'309 gal)**
- MAWP 18.5 bar (268 psi)
- inner vessel made of stainless steel

part no.

CO<sub>2</sub> 900830  
LIN, LOX, LAR 4046471



Pos. 012

## 73.0 t (160'938 lb) / 73'000 l vertical, vacuum insulated storage tank

Only available for CO<sub>2</sub> storage.

Tank to be supplied complete with all pipework in stainless steel, valves, safety devices, differential pressure liquid level indicator, vacuum insulated.

- diameter: 3'000 mm (118 in) / height: 16'400 mm (646 in)
- including registration by German TÜV according to PED 2014/68/EU and AD2000 (also for CH)

### CO<sub>2</sub>: (available options please see flow diagram no. 700)

- maximum filling weight of **69'930 kg (154'169 lb)**
- safety valve setting 22 bar (319 psi)
- inner vessel standardly made of carbon steel, also available in stainless steel

part no.

CO<sub>2</sub> 900751



## Vertical vacuum insulated ASCO Storage Tanks: Available standard capacities

Pos. 013

**100.0 t (220'462 lb) / 100'000 l vertical, vacuum insulated storage tank**

**part no.**

**Only available for CO<sub>2</sub> storage**

**CO<sub>2</sub>**

**900752**

Tank to be supplied complete with all pipework in stainless steel, valves, safety devices, differential pressure liquid level indicator, vacuum insulated.

- diameter: 3'600 mm (142 in) / height: 15'350 mm (604 in)
- including registration by German TÜV according to PED 2014/68/EU and AD2000 (also for CH)

**CO<sub>2</sub>: (available options please see flow diagram no. 700)**

- maximum filling weight of **95'800 kg (211'203 lb)**
- safety valve setting 22 bar (319 psi)
- inner vessel standardly made of carbon steel, also available in stainless steel
- available options please see flow diagram no. 700



## Horizontal vacuum insulated CO<sub>2</sub> Storage Tanks: Available standard capacities

Pos. 014

### 11.0 t (24'251 lb) / 11'000 l horizontal, vacuum insulated CO<sub>2</sub> storage tank

part no. 900804

Tank to be supplied complete with all pipework in stainless steel, valves, safety devices, differential pressure liquid level indicator, vacuum insulated.

- diameter: 2'200 mm (86.61 in) / length: 6'400 mm (252 in)
- including registration by German TÜV according to PED 2014/68/EU and AD2000 (also for CH)
- maximum filling weight of **10'540 kg (23'237 lb)**
- safety valve setting 24 bar (348 psi) (if stainless steel upgrade 22 bar) (319 psi)
- inner vessel standardly made of carbon steel, also available in stainless steel
- available options please see flow diagram no. 750



Pos. 015

### 17.0 t (37'478.6 lb) / 17'000 l horizontal, vacuum insulated CO<sub>2</sub> storage tank

part no. 900805

Tank to be supplied complete with all pipework in stainless steel, valves, safety devices, differential pressure liquid level indicator, vacuum insulated.

- diameter: 2'200 mm (87 in) / length: 9'000 mm (352 in)
- including registration by German TÜV according to PED 2014/68/EU and AD2000 (also for CH)
- maximum filling weight of **16'290 kg (35'919 lb)**
- safety valve setting 24 bar (348 psi) (if stainless steel upgrade 22 bar) (319 psi)
- inner vessel standardly made of carbon steel, also available in stainless steel
- available options please see flow diagram no. 750



Pos. 016

### 20.0 t (44'093 lb) / 20'000 l horizontal, vacuum insulated CO<sub>2</sub> storage tank

part no. 900906

Tank to be supplied complete with all pipework in stainless steel, valves, safety devices, differential pressure liquid level indicator, vacuum insulated.

- diameter: 2'200 mm (87 in) / length: 10'250 mm (404 in)
- including registration by German TÜV according to PED 2014/68/EU and AD2000 (also for CH)
- maximum filling weight of **19'160 kg (42'241 lb)**
- safety valve setting 24 bar (348 psi) (if stainless steel upgrade 22 bar) (319 psi)
- inner vessel standardly made of carbon steel, also available in stainless steel
- available options please see flow diagram no. 750



Pos. 017

## 28.0 t (61'729 lb) / 28'000 l horizontal, vacuum insulated CO<sub>2</sub> storage tank

part no. 900807

Tank to be supplied complete with all pipework in stainless steel, valves, safety devices, differential pressure liquid level indicator, vacuum insulated.

- diameter: 2'500 mm (98 in) / length: 10'400 mm (407 in)
- including registration by German TÜV according to PED 2014/68/EU and AD2000 (also for CH)
- maximum filling weight of **26'820 kg (59'128 lb)**
- safety valve setting 24 bar (348 psi) (if stainless steel upgrade 22 bar) (319 psi)
- inner vessel standardly made of carbon steel, also available in stainless steel
- available options please see flow diagram no. 750



Pos. 018

## 32.0 t (70'548 lb) / 32'300 l horizontal, vacuum insulated CO<sub>2</sub> storage tank

part no. 900808

Tank to be supplied complete with all pipework in stainless steel, valves, safety devices, differential pressure liquid level indicator, vacuum insulated.

- diameter: 2'500 mm (98 in) / length: 11'600 mm (457 in)
- including registration by German TÜV according to PED 2014/68/EU and AD2000 (also for CH)
- maximum filling weight of **30'660 kg (67'594 lb)**
- safety valve setting 24 bar (348 psi) (if stainless steel upgrade 22 bar) 319 psi)
- inner vessel standardly made of carbon steel, also available in stainless steel
- available options please see flow diagram no. 750



Pos. 019

## 37.0 t (81'571 lb) / 36'600 l horizontal, vacuum insulated CO<sub>2</sub> storage tank

part no. 900809

Tank to be supplied complete with all pipework in stainless steel, valves, safety devices, differential pressure liquid level indicator, vacuum insulated.

- diameter: 2'500 mm (98 in) / length: 12'900 mm (508 in)
- including registration by German TÜV according to PED 2014/68/EU and AD2000 (also for CH)
- maximum filling weight of **35'450 kg (78'154 lb)**
- safety valve setting 24 bar (348 psi) (if stainless steel upgrade 22 bar) (319 psi)
- inner vessel standardly made of carbon steel, also available in stainless steel
- available options please see flow diagram no. 750



## Horizontal vacuum insulated CO<sub>2</sub> Storage Tanks: Available standard capacities

Pos. 020

### 41.0 t (90'390 lb) / 41'000 l horizontal, vacuum insulated CO<sub>2</sub> storage tank

part no. 900810

Tank to be supplied complete with all pipework in stainless steel, valves, safety devices, differential pressure liquid level indicator, vacuum insulated.

- diameter: 2'500 mm (98 in) / length 14'150 mm (557 in)
- including registration by German TÜV according to PED 2014/68/EU and AD2000 (also for CH)
- maximum filling weight of **39'280 kg (86'598 lb)**
- safety valve setting 24 bar (348 psi)(if stainless steel upgrade 22 bar) (319 psi)
- inner vessel standardly made of carbon steel, also available in stainless steel
- available options please see flow diagram no. 750



Pos. 021

### 50.0 t (110'231 lb) / 50'000 l horizontal, vacuum insulated CO<sub>2</sub> storage tank

part no. 900811

Tank to be supplied complete with all pipework in stainless steel, valves, safety devices, differential pressure liquid level indicator, vacuum insulated.

- diameter: 3'000 mm (118 in) / length: 11'990 mm (472 in)
- including registration by German TÜV according to PED 2014/68/EU and AD2000 (also for CH)
- maximum filling weight of **47'900 kg (105'601 lb)**
- safety valve setting 24 bar (348 psi) (if stainless steel upgrade 22 bar) (319 psi)
- inner vessel standardly made of carbon steel, also available in stainless steel
- available options please see flow diagram no. 750





# CO<sub>2</sub> Storage

## ASCO CO<sub>2</sub> Storage Tanks Polyurethane Insulated



**ASCO** polyurethane insulated (PU) Storage Tanks are constructed in various standard sizes, ranging from 10t to 100t capacity of liquid carbon dioxide. Each unit is compactly designed, simple and safe to operate and easily installed.

The **ASCO** pressure vessels are designed and built per PED and AD2000, maximum allowable working pressure is 24 bar (348 psi). Tanks are supplied complete with all pipework in stainless steel, valves and safety devices (as described in our tank flow diagram).



**ASCO** PU insulated CO<sub>2</sub> Storage Tanks are available as vertical and horizontal version.

Insulated, completely pre-wired electrical system with control cabinet, level-indicator media6 or loadcell, pressure build-up heater, safety devices, valves, pipework. All our systems are completely pretested before shipment.

Capacities given is based on a 95 % full volume. Vessels are insulated with 150 to 200 mm (5.91 to 7.87 in) polyurethane foam, covered by an aluminium sheet and are primed.

The tank content can be shown either by differential pressure indicator and pressure gauge or load cells.

### Specifications

Pressure vessel:	Made of carbon steel, 24 bar (348 psi) design pressure
Insulation:	PU insulated, 150-200 mm (6-8 in), covered by aluminium sheet
Piping:	Stainless steel
Contents gauge:	Differential pressure measuring device (outlet 4-20 mA)
Filling connections:	According to flow diagram
Approval:	ED 2014/68/EU and AD2000

ASCO reserves the right to modify all specifications without prior notice.

## PU insulated ASCO CO<sub>2</sub> Storage Tanks: Overview standard capacities

### Available standard capacities vertical PU insulated ASCO CO<sub>2</sub> Storage Tanks:

Tank capacity (liquid CO <sub>2</sub> in kg) (lb)	Dimensions (height × diameter in mm) (in)	approx. empty weight in kg (lb)	part no.
9'800 (21'605)	5'250 × 1'800 (207 x 71)	4'800 (10'582)	4046602
14'700 (32'408)	7'250 × 1'800 (285 x 71)	5'300 (11'684)	4046603
17'650 (38'912)	8'750 × 1'800 (344 x 71)	6'500 (14'330)	4046604
22'550 (49'714)	10'250 × 1'800 (404 x 71)	7'800 (17'196)	4046605
29'500 (65'036)	8'250 × 2'400 (325 x 94)	9'500 (20'944)	4046606
39'150 (86'311)	9'750 × 2'400 (384 x 94)	11'200 (24'692)	4046607
48'900 (101'780)	12'550 × 2'400 (494 x 94)	13'600 (29'983)	4046608
58'700 (129'411)	14'550 × 2'400 (573 x 94)	14'850 (32'739)	4046609
97'850 (215'722)	14'000 × 3'200 (55 x 126)	25'800 (56'879)	4046610

### Available standard capacities horizontal PU insulated ASCO CO<sub>2</sub> Storage Tanks:

Tank capacity (liquid CO <sub>2</sub> in kg) (lb)	Dimensions (length × diameter in mm) (in)	approx. empty weight in kg (lb)	part no.
9'800 (21'605)	5'805 × 1'900 (229 x 75)	4'000 (8'818)	4046592
14'700(32'408)	7'305 × 1'900 (288 x 73)	5'000 (11'023)	4046593
17'650 (17'650)	8'800 × 1'900 (346 x 73)	6'000 (13'228)	4046594
22'550 (49'714)	10'300 × 1'900 (406 x 73)	7'000 (15'432)	4046595
29'500 (65'036)	11'800 × 1'900 (465 x 73)	8'600 (18'960)	4046596
39'150 (86'311)	10'800 × 2'400 (425 x 73)	10'300 (22'708)	4046597
48'900 (101'780)	14'000 × 2'400 (551 x 73)	13'600 (29'983)	4046598
58'700 (129'411)	15'500 × 2'400 (610 x 94)	15'000 (33'069)	4046599
97'850 (215'722)	13'500 × 3'000 (531 x 118)	29'500 (65'036)	4046600

All horizontal PU insulated ASCO CO<sub>2</sub> Storage Tanks are delivered skid-mounted.

## PU insulated ASCO CO<sub>2</sub> Storage Tanks: Standard scope of supply

- back-up valves on filling liquid and gas line
- 2 liquid withdrawal valves
- 2 gas withdrawal valves
- refrigeration coil

**Additionally either a load cell or a differential pressure indicator (Media 7) has to be chosen (see options).**

## Vertical PU insulated ASCO CO<sub>2</sub> Storage Tanks: Available standard capacities

Pos. 001

### ASCO CO<sub>2</sub> VT PU Storage Tank, 10 t (22'046 lb) TÜV/PED

part no. 4046602

10 t vertical, with a maximum filling weight of **9'800 kg (21'605 lb)**

- diameter: 1'800 mm (71 in) / height: 5'300 mm (207 in)
- empty weight: approx. 4'800 kg (10'582 lb)
- working temperature: -40 °C to +50 °C

Safety valve setting 24 bar (348 psi), vessel made of carbon steel, PU insulated

Tank to be supplied complete with all pipework in stainless steel, valves and safety devices.

Incl.:

- back-up valves on filling liquid and gas line
- 2 liquid withdrawal valves
- 2 gas withdrawal valves
- refrigeration coil



Pos. 002

### ASCO CO<sub>2</sub> VT PU Storage Tank, 15 t (33'069 lb) TÜV/PED

part no. 4046603

15 t vertical, with a maximum filling weight of **14'700 kg (32'408 lb)**

- diameter: 1'800 mm (71 in) / height: 7'300 mm (285 in)
- empty weight: approx. 5'300 kg (11'685 lb)
- working temperature: -40 °C to +50 °C

Safety valve setting 24 bar (348 psi), vessel made of carbon steel, PU insulated

Tank to be supplied complete with all pipework in stainless steel, valves and safety devices.

Incl.:

- back-up valves on filling liquid and gas line
- 2 liquid withdrawal valves
- 2 gas withdrawal valves
- refrigeration coil



Pos. 003

### ASCO CO<sub>2</sub> VT PU Storage Tank, 18 t (39'683 lb) TÜV/PED

part no. 4046604

18 t vertical, with a maximum filling weight of **17'650 kg (38'912 lb)**

- diameter: 1'800 mm (71 in) / height: 8'880 mm (344 in)
- empty weight: approx. 6'500 kg (14'110 lb)
- working temperature: -40 °C to +50 °C
- 

Safety valve setting 24 bar (348 psi), vessel made of carbon steel, PU insulated

Tank to be supplied complete with all pipework in stainless steel, valves and safety devices.

Incl.:

- back-up valves on filling liquid and gas line
- 2 liquid withdrawal valves
- 2 gas withdrawal valves
- refrigeration coil



## Vertical PU insulated ASCO CO<sub>2</sub> Storage Tanks: Available standard capacities

Pos. 004

### ASCO CO<sub>2</sub> VT PU Storage Tank, 23 t (50'706 lb) TÜV/PED

part no. 4046605

23 t vertical, with a maximum filling weight of **22'550 kg (49'714.24 lb)**

- diameter: 1'800 mm (71 in) / height: 10'300 mm (404 in)
- empty weight: approx. 7'800 kg (17'196 lb)
- working temperature: -40 °C to +50 °C

Safety valve setting 24 bar (348 psi), vessel made of carbon steel, PU insulated

Tank to be supplied complete with all pipework in stainless steel, valves and safety devices.

Incl.:

- back-up valves on filling liquid and gas line
- 2 liquid withdrawal valves
- 2 gas withdrawal valves
- refrigeration coil



Pos. 005

### ASCO CO<sub>2</sub> VT PU Storage Tank, 30 t (66'139 lb) TÜV/PED

part no. 4046606

30 t vertical, with a maximum filling weight of **29'500 kg (65'036 lb)**

- diameter: 2'400 mm (94 in) / height: 8'300 mm (325 in)
- empty weight: approx. 9'500 kg (20'944 lb)
- working temperature: -40 °C to +50 °C

Safety valve setting 24 bar (348 psi), vessel made of carbon steel, PU insulated

Tank to be supplied complete with all pipework in stainless steel, valves and safety devices.

Incl.:

- back-up valves on filling liquid and gas line
- 2 liquid withdrawal valves
- 2 gas withdrawal valves
- refrigeration coil



Pos. 006

### ASCO CO<sub>2</sub> VT PU Storage Tank, 40 t (88'185 lb) TÜV/PED

part no. 4046607

40 t vertical, with a maximum filling weight of **39'150 kg (86'311 lb)**

- diameter: 2'400 mm (94 in) / height: 9'800 mm (384 in)
- empty weight: approx. 11'200 kg (24'692 lb)
- working temperature: -40 °C to +50 °C

Safety valve setting 24 bar (348 psi), vessel made of carbon steel, PU insulated

Tank to be supplied complete with all pipework in stainless steel, valves and safety devices.

Incl.:

- back-up valves on filling liquid and gas line
- 2 liquid withdrawal valves
- 2 gas withdrawal valves
- refrigeration coil



## Vertical PU insulated ASCO CO<sub>2</sub> Storage Tanks: Available standard capacities

Pos. 007

### ASCO CO<sub>2</sub> VT PU Storage Tank, 50 t (110'231 lb) TÜV/PED

part no. 4046608

50 t vertical, with a maximum filling weight of **48'900 kg (107'806 lb)**

- diameter: 2'400 mm (94 in) / height: 12'600 mm (494 in)
- empty weight: approx. 13'600 kg (29'983 lb)
- working temperature: -40 °C to +50 °C

Safety valve setting 24 bar (348 psi), vessel made of carbon steel, PU insulated

Tank to be supplied complete with all pipework in stainless steel, valves and safety devices.

Incl.:

- back-up valves on filling liquid and gas line
- 2 liquid withdrawal valves
- 2 gas withdrawal valves
- refrigeration coil



Pos. 008

### ASCO CO<sub>2</sub> VT PU Storage Tank, 60 t (132'277 lb) TÜV/PED

part no. 4046609

60 t vertical, with a maximum filling weight of **58'700 kg (139'411 lb)**

- diameter: 2'400 mm (94 in) / height: 14'600 mm (573 in)
- empty weight: approx. 14'850 kg (32'739 lb)
- working temperature: -40 °C to +50 °C

Safety valve setting 24 bar (348 psi), vessel made of carbon steel, PU insulated

Tank to be supplied complete with all pipework in stainless steel, valves and safety devices.

Incl.:

- back-up valves on filling liquid and gas line
- 2 liquid withdrawal valves
- 2 gas withdrawal valves
- refrigeration coil



Pos. 009

### ASCO CO<sub>2</sub> VT PU Storage Tank, 100 t (220'462 lb) TÜV/PED

part no. 4046610

100 t vertical, with a maximum filling weight of **97'850 kg (215'722 lb)**

- diameter: 3'200 mm (126 in) / height: 14'000 mm (551 in)
- empty weight: approx. 25'800 kg (56'879 lb)
- working temperature: -40 °C to +50 °C

Safety valve setting 24 bar (348 psi), vessel made of carbon steel, PU insulated

Tank to be supplied complete with all pipework in stainless steel, valves and safety devices.

Incl.:

- back-up valves on filling liquid and gas line
- 2 liquid withdrawal valves
- 2 gas withdrawal valves
- refrigeration coil



## Pos. 010

### ASCO CO<sub>2</sub> HT PU Storage Tank, 10t TÜV/PED

part no. 4046592

10t horizontal, with a maximum filling weight of **9'800 kg (21'605 lb)**

- diameter: 1'900 mm (75 in) / length: 5'805 mm (229 in)
- empty weight: approx. 4'000 kg (8'818 lb)
- working temperature: -40 °C to +50 °C



Safety valve setting 24 bar (348 psi), vessel made of carbon steel, PU insulated

Tank to be supplied complete with all pipework in stainless steel, valves and safety devices, skid-mounted.

Incl.:

- back-up valves on filling liquid and gas line
- 2 liquid withdrawal valves
- 2 gas withdrawal valves
- refrigeration coil

## Pos. 011

### ASCO CO<sub>2</sub> HT PU Storage Tank, 15t TÜV/PED

part no. 4046593

15t horizontal, with a maximum filling weight of **14'700 kg (32'408 lb)**

- diameter: 1'900 mm (75 in) / length: 7'305 mm (288 in)
- empty weight: approx. 5'000 kg (11'027 lb)
- working temperature: -40 °C to +50 °C



Safety valve setting 24 bar (348 psi), vessel made of carbon steel, PU insulated

Tank to be supplied complete with all pipework in stainless steel, valves and safety devices, skid-mounted.

Incl.:

- back-up valves on filling liquid and gas line
- 2 liquid withdrawal valves
- 2 gas withdrawal valves
- refrigeration coil

## Pos. 012

### ASCO CO<sub>2</sub> HT PU Storage Tank, 18t TÜV/PED

part no. 4046594

18t horizontal, with a maximum filling weight of **17'650 kg (38'912 lb)**

- diameter: 1'900 mm (75 in) / length: 8'800 mm (346 in)
- empty weight: approx. 6'000 kg (13'228 lb)
- working temperature: -40 °C to +50 °C



Safety valve setting 24 bar (348 psi), vessel made of carbon steel, PU insulated

Tank to be supplied complete with all pipework in stainless steel, valves and safety devices, skid-mounted.

Incl.:

- back-up valves on filling liquid and gas line
- 2 liquid withdrawal valves
- 2 gas withdrawal valves
- refrigeration coil

## Pos. 013

### ASCO CO<sub>2</sub> HT PU Storage Tank, 23t TÜV/PED

part no. 4046595

23t horizontal, with a maximum filling weight of **22'550 kg (49'714 lb)**

- diameter: 1'900 mm (75 in) / length: 10'300 mm (406 in)
- empty weight: approx. 7'000 kg (15'432 lb)
- working temperature: -40 °C to +50 °C



Safety valve setting 24 bar (348 psi), vessel made of carbon steel, PU insulated

Tank to be supplied complete with all pipework in stainless steel, valves and safety devices, skid-mounted.

Incl.:

- back-up valves on filling liquid and gas line
- 2 liquid withdrawal valves
- 2 gas withdrawal valves
- refrigeration coil

## Pos. 014

### ASCO CO<sub>2</sub> HT PU Storage Tank, 30t TÜV/PED

part no. 4046596

30t horizontal, with a maximum filling weight of **29'500 kg (65'036 lb)**

- diameter: 1'900 mm (75 in) / length: 11'800 mm (465 in)
- empty weight: approx. 8'600 kg (18'960 lb)
- working temperature: -40 °C to +50 °C



Safety valve setting 24 bar (348 psi), vessel made of carbon steel, PU insulated

Tank to be supplied complete with all pipework in stainless steel, valves and safety devices, skid-mounted.

Incl.:

- back-up valves on filling liquid and gas line
- 2 liquid withdrawal valves
- 2 gas withdrawal valves
- refrigeration coil

## Pos. 015

### ASCO CO<sub>2</sub> HT PU Storage Tank, 40t TÜV/PED

part no. 4046597

40t horizontal, with a maximum filling weight of **39'150 kg (86'311 lb)**

- diameter: 2'400 mm (95 in) / length: 10'800 mm (425 in)
- empty weight: approx. 10'300 kg (22'708 lb)
- working temperature: -40 °C to +50 °C



Safety valve setting 24 bar (348 psi), vessel made of carbon steel, PU insulated

Tank to be supplied complete with all pipework in stainless steel, valves and safety devices, skid-mounted.

Incl.:

- back-up valves on filling liquid and gas line
- 2 liquid withdrawal valves
- 2 gas withdrawal valves
- refrigeration coil

## Horizontal PU insulated ASCO CO<sub>2</sub> Storage Tanks: Available standard capacities

Pos. 016

### ASCO CO<sub>2</sub> HT PU Storage Tank, 50t TÜV/PED

50t horizontal, with a maximum filling weight of **48'900 kg (107'806 lb)**

- diameter: 2'400 mm (95 in) / length: 14'000 mm (551 in)
- empty weight: approx. 13'600 kg (29'983 lb)
- working temperature: -40 °C to +50 °C

Safety valve setting 24 bar (348 psi), vessel made of carbon steel, PU insulated

Tank to be supplied complete with all pipework in stainless steel, valves and safety devices, skid-mounted.

Incl.:

- back-up valves on filling liquid and gas line
- 2 liquid withdrawal valves
- 2 gas withdrawal valves
- refrigeration coil

part no. 4046598



Pos. 017

### ASCO CO<sub>2</sub> HT PU Storage Tank, 60t TÜV/PED

60t horizontal, with a maximum filling weight of **58'700 kg (129'411 lb)**

- diameter: 2'400 mm (95 in) / length: 15'500 mm (610 in)
- empty weight: approx. 15'000 kg (33'069 lb)
- working temperature: -40 °C to +50 °C

Safety valve setting 24 bar (348 psi), vessel made of carbon steel, PU insulated

Tank to be supplied complete with all pipework in stainless steel, valves and safety devices, skid-mounted.

Incl.:

- back-up valves on filling liquid and gas line
- 2 liquid withdrawal valves
- 2 gas withdrawal valves
- refrigeration coil

part no. 4046599



Pos. 018

### ASCO CO<sub>2</sub> HT PU Storage Tank, 100t TÜV/PED

100t horizontal, with a maximum filling weight of **97'850 kg (215'722 lb)**

- diameter: 3'000 mm (118 in) / length: 13'500 mm (532 in)
- empty weight: approx. 29'500 kg (65'036 lb)
- working temperature: -40 °C to +50 °C

Safety valve setting 24 bar (348 psi), vessel made of carbon steel, PU insulated

Tank to be supplied complete with all pipework in stainless steel, valves and safety devices, skid-mounted.

Incl.:

- back-up valves on filling liquid and gas line
- 2 liquid withdrawal valves
- 2 gas withdrawal valves
- refrigeration coil

part no. 4046600





## Vertical & horizontal PU insulated ASCO CO<sub>2</sub> Storage Tanks: Options

Pos. 019

**Refrigeration unit for ASCO CO<sub>2</sub> H/VT PU10-30 t Storage Tank**

**part no. 4046612**

Pos. 020

**Refrigeration unit for ASCO CO<sub>2</sub> H/VT PU 40-100 t Storage Tank**

**part no. 4046613**

Pos. 021

**Heating unit for ASCO CO<sub>2</sub> H/VT PU Storage Tank**

**part no. 4046614**

Heating unit to hold the pressure stable inside the tank

Pos. 022

**Load cell for ASCO CO<sub>2</sub> H/VT PU Storage Tank 40-100 t**

**part no. 4046615**

Load cell instead of differential pressure indicator Media 7

Pos. 023

**Media 7 for ASCO CO<sub>2</sub> H/VT PU Storage Tank**

**part no. 4046616**

Differential pressure indicator Media 7 for liquid level indication instead of load cell

**Please note that the standard version of the tanks is NOT equipped with any filling level indication! Therefore one of the options (part no. 4046615 or 4046616) must be chosen.**

# CO<sub>2</sub> Storage

## ASCO 20' ISO Tank Containers



**ASCO CO<sub>2</sub>** and Cryogenic 20' ISO Tank Containers include a high quality vacuum multi-laminar super insulation and are supplied complete with all pipework, valves, safety devices, liquid level indicator, pressure gauge and optional with transfer pump and filling hoses.

All tank containers are designed for transportation by road, ship and rail.

The models are also available on semi-trailer and/or with tractor.

Inner vessels and pipework are made of stainless steel-used for multipurpose transportation of CO<sub>2</sub>, N<sub>2</sub>, O<sub>2</sub> and Ar.

ASCO reserves the right to modify all specifications without prior notice.

## Specifications:

### 1. Main Data

Commodity	approx. 19'650 l (5'191 gal)
Gross water volume:	19'650 l
Max. allowed working pressure:	22 bar (319 psi)
Tare weight:	approx 8'600 kg (18'960 lb)
Max. gross weight:	36'000 kg (79'366 lb)
Max. payload:	LCO <sub>2</sub> : approx. 19'600 kg (43'211 lb)
	LIN: approx. 14'950 kg (32'959 lb)
	LOX: approx. 21'240 kg (46'826 lb)
	LAR: approx. 26'130 kg (57'607 lb)
Tolerances:	on volume 1 %, on weight 2 %
Codes and regulations:	ADR / RID / IMDG / (UN-T75) / UIC
Insulation:	Vacuum with multi-layer insulation
Height:	approx. 2'600 mm (102 in)
Width:	approx 2'440 mm (96 in)
Overall length:	6'060 mm (239 in)
ISO-corner castings:	20' x 8' x 8'6" ISO dimensions (508 x 203.2 x 218.4 mm)

### 2. Tank

<b>Inner Vessel</b>	
Max. allowed working pressure:	22 bar (319 psi)
Pressure vessel code:	AD 2000-Regelwerk
Test and calculation pressure:	29.9 bar (434 psi)
Design temperature:	-196 / +50 °C
Outer diameter:	2'200 mm (87 in)
Number of baffles:	2
<b>Outer Vessel</b>	
Design pressure:	-1 bar (-14.5 psi) (full vacuum)
Design temperature:	-20 / +50 °C
Outer diameter:	2'420 mm (95.28 in) (not protruding over the frame members)
Overall length:	6'000 mm (236.22 in) (not protruding over the frame members)
<b>Insulation</b>	
Type	vacuum + multi-layer insulation (super insulated)
<b>Materials</b>	
Inner vessel of CO <sub>2</sub> tanks:	Stainless steel type 1.4311/EN 10028-7 or equivalent
Inner vessel of cryogenic tanks:	Stainless steel type 1.4311/DIN 17440 or equivalent
Outer vessel:	Carbon steel S235JRG2/EN 10025 or equivalent
Piping:	Stainless steel type 304 (L)
Valves for CO <sub>2</sub> tanks:	Ball valves, stainless steel, for CO <sub>2</sub>
Valves for cryogenic tanks	Cryogenic valves

### 3. Frame

The frame is of „Beam Type“, consisting 8' x 8'6"-frame at each end, connected to each end. Handling to be done by means of the corner castings only. The container can be secured by twist locks on rail and road vehicles complying to the relevant requirements of ISO 668 freight containers.

## Lockable Machinery Compartment:

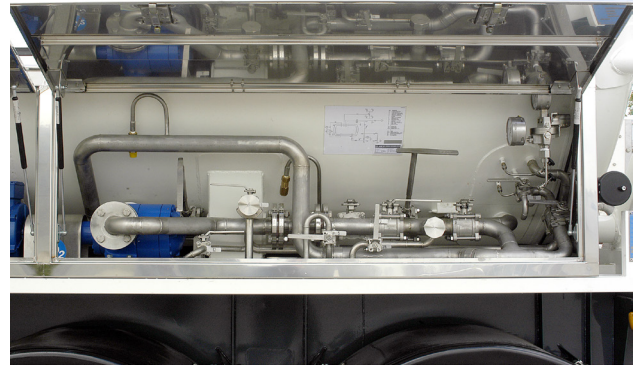
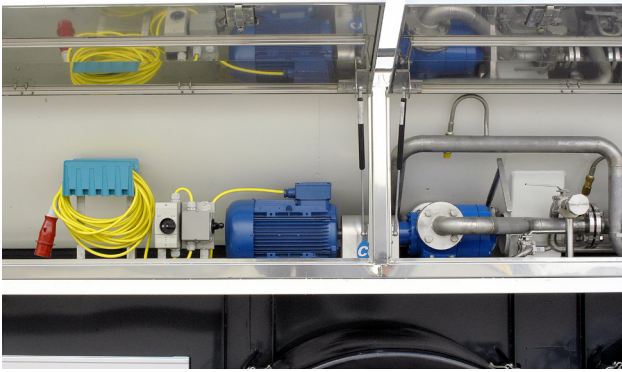

All stainless steel pipework and valves neatly arranged in a lockable machinery compartment. Outside of the machinery compartment is a lockable document holder installed.

## Available Types:



ASCO's 20' ISO Tank Containers are optionally available on semi-trailer and/or tractor.

All ISO tank containers include:

- inner vessel made of **stainless steel**
- all pipe work made of **stainless steel**
- all valving necessary for proper operation (stainless steel ball valves for CO<sub>2</sub> and bronze globe valves for cryogenic)
- all necessary safety equipment
- all instruments and safety lines that form part of the tank, including pressure and level gauge
- transfer pump and filling hoses (optional)

Larger sizes also available. Please ask for details!

# ASCO 20' ISO Tank Container

Typical flow diagram for 20' ASCO ISO Tank Cryogenic Container

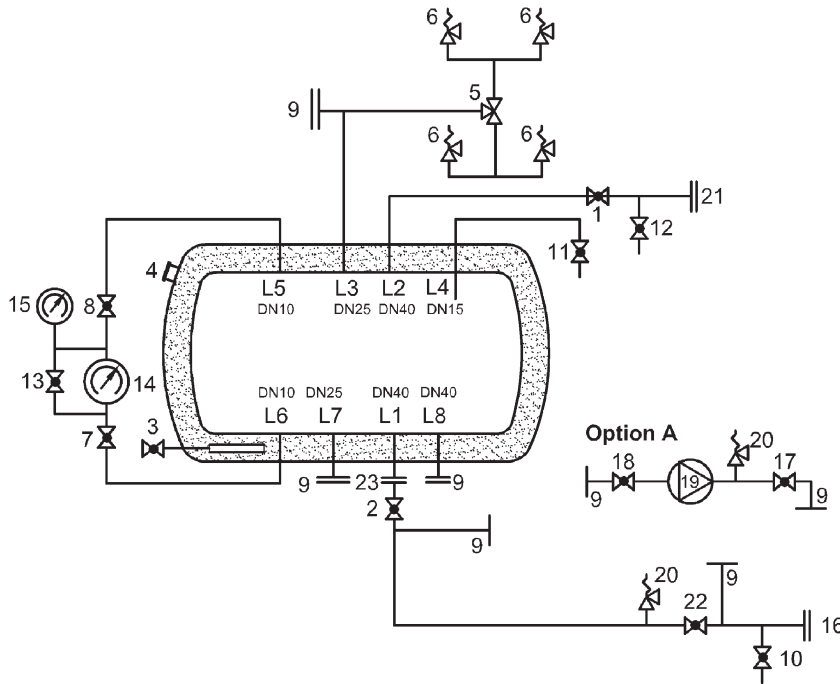

- 1 Vapour balance line valve
- 2 Main bottom isolation valve
- 3 Vacuum point
- 4 Bursting disc vacuum jacket
- 5 Divertor valve
- 6 Safety valve
- 7 Instrument liquid valve
- 8 Instrument gas valve
- 9 Flange connection with blindflange (without option)
- 10 Fill and discharge line purge valve
- 11 Trycock nett capacity 95% valve
- 12 Vapour line purge valve
- 13 Level gauge balance line valve
- 14 Liquid gauge level
- 15 Pressure gauge
- 16 Connection fill and discharge line (flange coupling)
- 17 Liquid from pump delivery valve
- 18 Pump isolation valve
- 19 Pump
- 20 Thermal relief valve
- 21 Connection vapour line (flange coupling)
- 22 Fill and discharge valve
- 23 Flange connection

Typical flow diagram for 20' ASCO ISO Tank CO<sub>2</sub> Container

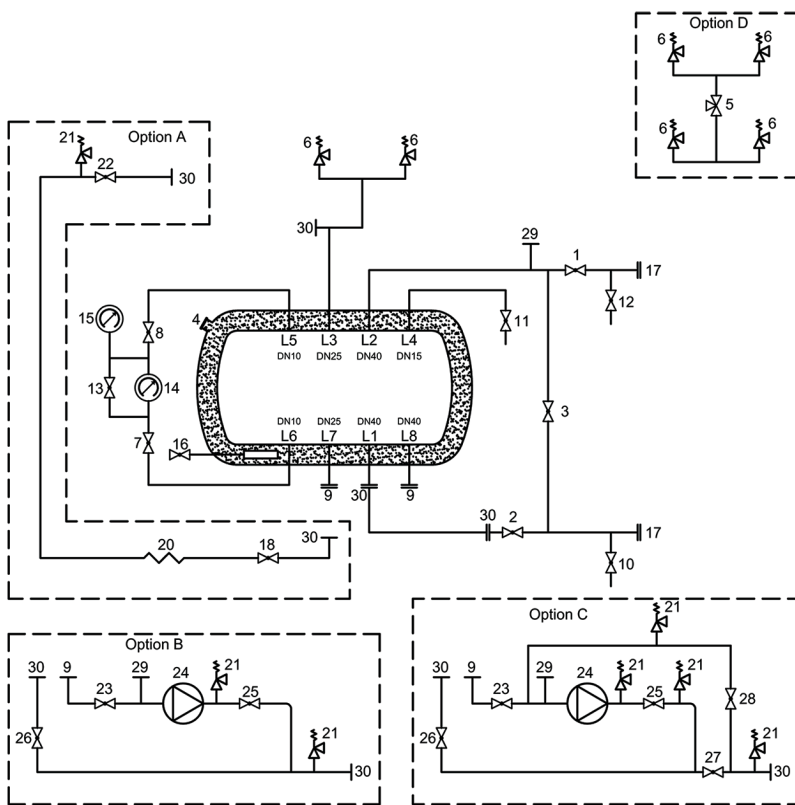

- 1 Vapour balance line valve
- 2 Bottom fill isolation valve
- 3 Top fill isolation valve
- 4 Bursting disc vacuum jacket
- 5 Divertor valve
- 6 Safety valve
- 7 Instrument liquid valve
- 8 Instrument gas valve
- 9 Flange connection with blindflange (without option)
- 10 Fill line purge valve
- 11 Trycock nett capacity 95% valve
- 12 Vapour line purge valve
- 13 Level gauge balance line valve
- 14 Liquid gauge level valve
- 15 Pressure gauge
- 16 Vacuum point
- 17 Flange connection with blindflange
- 18 Liquid to pressure build up valve
- 19 Pump
- 20 Fin vaporiser
- 21 Thermal relief valve
- 22 Pressure build up gas return valve
- 23 Liquid to pump fill valve
- 24 Pump
- 25 Liquid from pump delivery valve
- 26 Pump by-pass valve
- 27 Liquid from pump delivery valve
- 28 Bottom fill pump isolation valve
- 29 Coupling with plug
- 30 Flange connection

## 20' ASCO ISO Tank Container: Available standard capacities

Pos. 001

### ASCO CO<sub>2</sub> 20' ISO Tank Container

Vacuum super insulated 20' ISO tank container (UN-T75) with stainless steel inner vessel, including hose box.

Gross water volume: approx. 19'650 l  
Max allowed working pressure: 22 bar (319 psi)  
Tare weight: approx. 8'600 kg (18'960 lb)  
Max. gross weight: 36'000 kg (79'366 lb)  
Max. payload: approx: **LCO<sub>2</sub>: 19'600 kg (43'211 lb)**

part no. 4046396



Optionally available on semi-trailer and/or tractor.

All ISO tank container include:

- inner vessel made of stainless steel
- all pipework made of stainless steel
- all valving necessary for proper operation
- all necessary safety equipment
- all instruments and safety lines that form part of the tank, including pressure and level gauge
- optionally transfer pump and filling hoses are available

Pos. 002

### Cryogenic ASCO 20' ISO Tank Container

Vacuum super insulated 20' ISO tank container (UN-T75) with stainless steel inner vessel, including hose box.

Gross water volume: approx. 19'650 l  
Max allowed working pressure: 22 bar (319 psi)  
Tare weight: approx. 8'600 kg (18'960 lb)  
Max. gross weight: 36'000 kg (79'366 lb)  
Max. payload: approx: **LIN: 14'950 kg (32'959 lb)**  
**LOX: 21'240 kg (46'826 lb)**  
**LAR: 26'130 kg (57'607 lb)**

part no. 4046398



Optionally available on semi-trailer and/or tractor.

All ISO tank container include:

- inner vessel made of stainless steel
- all pipework made of stainless steel
- all valving necessary for proper operation
- all necessary safety equipment
- all instruments and safety lines that form part of the tank, including pressure and level gauge
- optionally transfer pump and filling hoses are available

# CO<sub>2</sub> Storage

## ASCO Transportable CO<sub>2</sub> Tanks / ASCO CO<sub>2</sub> Semi-Trailers



**ASCO** supplies different sizes of transportable CO<sub>2</sub> tanks which can be mounted on any suitable truck or trailer locally. Transportable tanks are a cost saving alternative to conventional road tankers as the operator may use the vehicle for other duties as well as bulk CO<sub>2</sub> transport. The tank is a self-contained unit mounted on a base frame and when empty it can easily be craned on or off as required. Suitable lifting lugs are on the top of the tank.

While transportable (dismountable) CO<sub>2</sub> tanks provide cost efficiency, our CO<sub>2</sub> semi-trailers provide even more logistics efficiency.



The special design of both our transportable CO<sub>2</sub> tanks and semi-trailers allows simple operation. A lockable machinery compartment houses the transfer pump and motor, control valves, contents and pressure gauges and pipework.

### ASCO Transportable CO<sub>2</sub> Tanks and CO<sub>2</sub> Semi-Trailers: Key features

- Short loading and unloading times thanks to proven design and user-ergonomics
- Highest possible capacity and lowest tare weight without compromising safety and durability, paying back customer's investments very early
- Special insulation considering least possible evaporation rate under extreme temperatures of different countries
- Versatile and adjustable design to be in conformity with different national standards
- Easy maintenance with highly accessible equipment panel, durable accessories
- Piping instrumentation design assuring maximum efficiency and safety

## Transportable ASCO CO<sub>2</sub> Tanks/CO<sub>2</sub> Semi-Trailers: Available standard capacities

Pos. 001

### ASCO CO<sub>2</sub> TPU transportable LCO<sub>2</sub> Tank, 6 m<sup>3</sup> (212 ft<sup>3</sup>)

part no. 4046547

6 m<sup>3</sup> PUR insulated truck mountable LCO<sub>2</sub> transport tank  
incl. Smith MC-3H LCO<sub>2</sub> transfer pump with flexible hoses 5 m

Gross volume:	6'098 litres (1'611 gal)
Net volume (% 95):	5'793 litres (1'530 gal)
Empty weight:	approx. 3'750 kg (8'267 lb)
Max. filling weight:	approx. 6'123 kg (13'499 lb)
Max. total weight:	approx. 9'873 kg (21'766 lb)
MDMT at mAWP:	-40 °C
Test Temp:	min. 10 °C / max. 40 °C
MAWP:	24 bar (348 psi)
Thermal insulation:	PUR insulation



Pos. 002

### ASCO CO<sub>2</sub> TPU transportable LCO<sub>2</sub> Tank, 12 m<sup>3</sup> (424 ft<sup>3</sup>)

part no. 4046548

12 m<sup>3</sup> PUR insulated truck mountable LCO<sub>2</sub> transport tank  
incl. Smith MC-3H LCO<sub>2</sub> transfer pump with flexible hoses 5 m

Gross volume:	12'127 litres (3'204 gal)
Net volume (% 95):	11'520 litres (3'043 gal)
Empty weight:	approx. 4'500 kg (9'921 lb)
Max. filling weight:	approx. 10'638 kg (23'453 lb)
Max. total weight:	approx. 15'138 kg (33'374 lb)
MDMT at mAWP:	-40 °C
Test Temp:	min. 10 °C / max. 40 °C
MAWP:	24 bar (348 psi)
Thermal insulation:	PUR insulation



Pos. 003

### ASCO CO<sub>2</sub> Semi-Trailer 25 m<sup>3</sup> (883 ft<sup>3</sup>) PUR

part no. 4046544

incl. Smith MC-3H LCO<sub>2</sub> transfer pump with flexible hoses 5 m  
equipped with OSMAN KOC brand axles

Insulation:	Polyurethan
Gross volume:	25'000 litres (6'604 gal)
Net volume (% 95):	23'750 litres (6'274 gal)
MAWP:	24 bar (348 psi)
Max. payload:	24'627 kg (54'293 lb)
Gross vehicle weight:	35'000 kg (77'162 lb)
Electrical system:	24 V
Truck requirements:	king-pin height 1'250 mm (49 in)
Tests:	Designs, calculations, visual dimensions and radiographic control are performed under the inspection of Bureau Veritas.



## Available Options:

Pos. 004

### LCO<sub>2</sub> flowmeter system

part no. 4046545

Flowmeter system for transportable tanks and semi-trailers

Electronic acquisition, display, recording, analysis, remote transmission and archiving of analog and digital input signals. The device will be installed into the tank/semi-trailer.

Pos. 005

### BPW Eco Plus Suspension Axles for ASCO Semi-Trailer

part no. 4046546

Optional axle system for ASCO LCO<sub>2</sub> Semi-Trailer 24.2 m<sup>3</sup> (855 ft<sup>3</sup>)



# CO<sub>2</sub> Gas Dosing for Water Neutralisation

## ASCO CO<sub>2</sub> Gas Dosing Systems



**ASCO CO<sub>2</sub> Dosing System (single line)**

Wherever you need to have an exact quantity of CO<sub>2</sub> gas to be dosed, the **ASCO** CO<sub>2</sub> Gas Dosing System is ideal! Typically, the **ASCO** CO<sub>2</sub> Gas Dosing System is used together with water desalination plants.

The system is equipped with a CO<sub>2</sub> pressure reducing valve, filtration unit, CO<sub>2</sub> gas flowmeter, CO<sub>2</sub> regulating valve, pressure gauges, safety valves and a completely pre-wired control cabinet.

In case of maintenance the system provides a manual by-pass line, which also can be monitored by the flowmeter. Herefore, changing a filter cartridge or doing any other service work on the system is quick and easy!

As raw and fitting material **ASCO** uses mainly stainless steel. This makes the system very resistant and extends the products life cycle.

### Advantages of an ASCO CO<sub>2</sub> Gas Dosing System:

- easy to install
- very accurate
- 4-20mA output signal
- robust stainless steel construction
- no auxiliary equipment like air compressor needed, only power supply is required

### Site conditions

Min. ambient air temperature:	10 °C, optional with heater for vaporiser down to 4 °C
Max. ambient air temperature:	38 °C, optional with air conditioned cabinet up to 50 °C
Humidity:	34 % to 99 %
Wind speed max:	19.03 m/s (62 ft/s), tank foundation must be recalculated by local civil engineer
Uniform building code:	seismic zone 2A
Temperature treated water:	15 to 35 °C
Side stream water pressure:	4 bar (58 psi) max.

## ASCO CO<sub>2</sub> Gas Dosing System: Components



- flanged inlet incl. counter flange
- control cabinet
- all equipment mounted on robust stainless steel frame

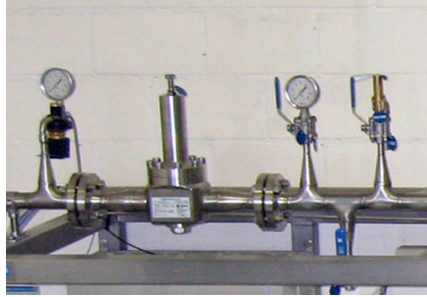

- pressure reducing valve for easy adjustment of inlet pressure



- **ASCO CO<sub>2</sub> Gas Flowmeter** for accurate measuring of the flow rate
- provides a 4-20 mA output signal which can be processed on the customer's main control

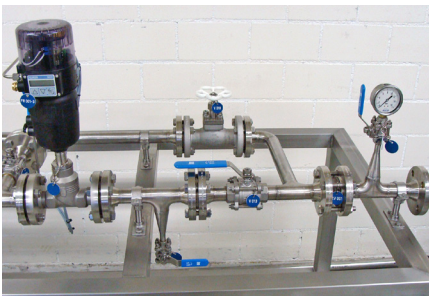

- actuating valve to adjust flow of CO<sub>2</sub> gas

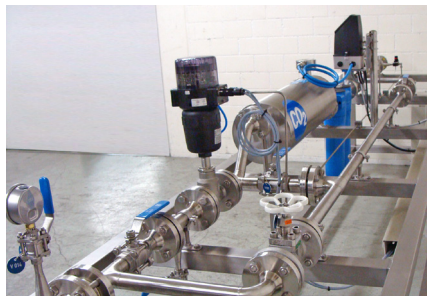

- by-pass-line for manual operation



- filtration unit

## Static mixer / Gas dispersion system

As per customer's requirement, **ASCO** includes static mixers or a complete gas dispersion system in order to ensure a reliable solubility of the CO<sub>2</sub> gas in the customer's main stream water. The used components feature the following key benefits:

- highly efficient mixing
- low energy consumption
- no moving parts for maintenance free operation
- no direct motive power required



CO<sub>2</sub> feeding via side stream into the main water stream



Reliable solubility of the CO<sub>2</sub> gas thanks to special design of the static mixer

## ASCO CO<sub>2</sub> Gas Dosing System: Example layout of a single line

Please note that all systems in this catalogue are only examples. Each system is customised and requires detailed engineering.

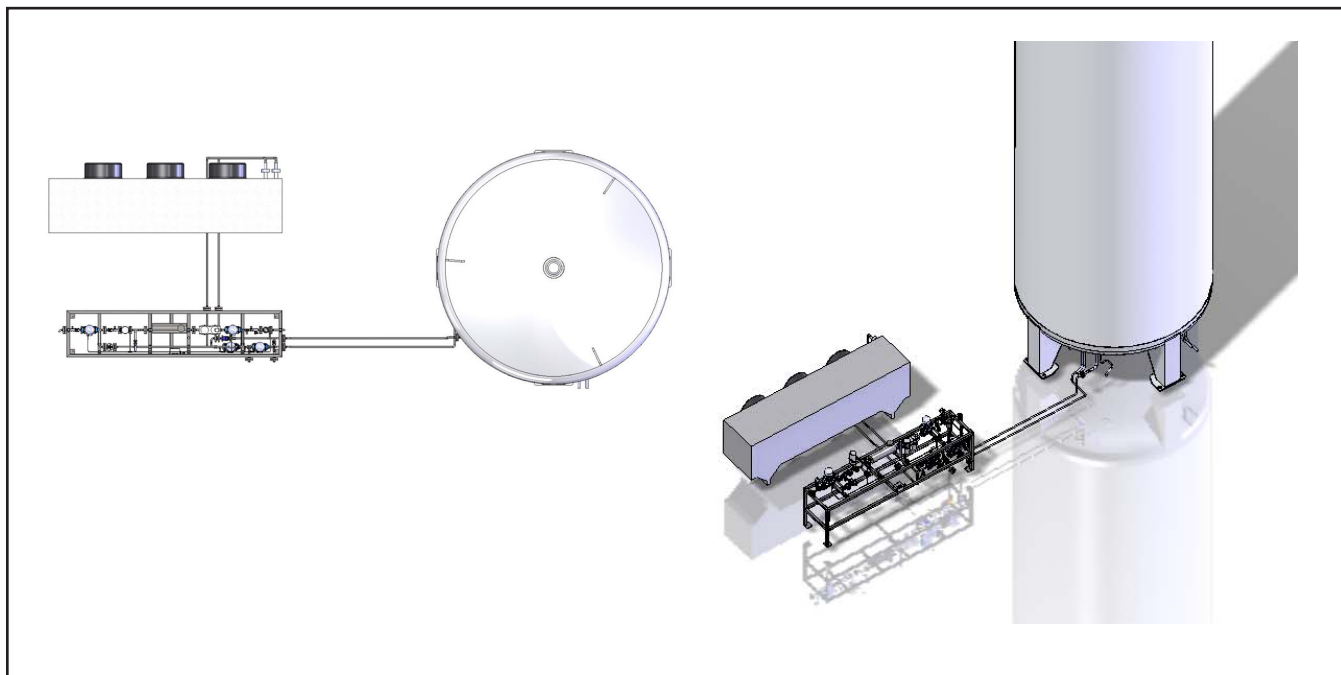

Example layout of a complete **ASCO** CO<sub>2</sub> Gas Dosing System (single line) with CO<sub>2</sub> tank and vaporiser

**ASCO** supplies a fully preinstalled and pretested system consisting of one storage tank, one vaporiser, one dosing system and, if desired, static mixers or a complete gas dispersion system.

The pipework of the **ASCO** CO<sub>2</sub> Gas Dosing System is completely welded to minimise installation works on site. Only the connection between storage tank and vaporiser has to be welded directly on site.

All civil related works, like site planning, foundations, electrical supply, installation material, water side stream and installation on site are customer's responsibility.

## ASCO CO<sub>2</sub> Gas Dosing System: Standard scope of supply (single line)

**ASCO** supplies a fully preinstalled and pretested system consisting of:

- 1 × **ASOC** CO<sub>2</sub> Gas Dosing System line consisting of
  - filtration unit
  - flow regulating valve
  - automatic shut off valve
  - pressure reducing valve
  - manual shut off valve
  - safety valves
  - discharge valve
  - control cabinet, prewired
  - all mounted on a stainless steel base frame
- 1 × CO<sub>2</sub> flowmeter including digital display
- 1 × CO<sub>2</sub> storage tank (capacity has to be specified at time of order)
- 1 × atmospheric CO<sub>2</sub> vaporiser (capacity has to be specified at time of order)
- 1 × static mixer or gas dispersion system (capacity has to be specified at time of order)

## ASCO CO<sub>2</sub> Gas Dosing System: Example Layout of a redundant dosing system

Please note that all systems in this catalogue are only examples. Each system is customised and requires detailed engineering.

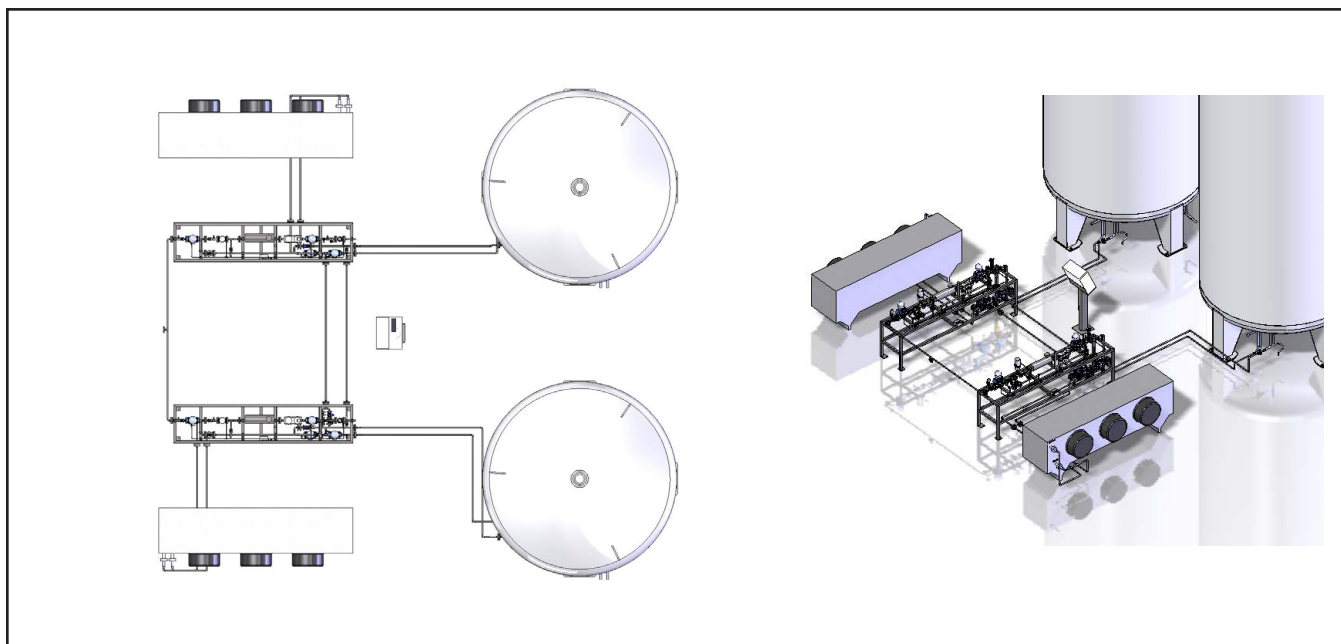

Example layout of a complete redundant **ASCO** CO<sub>2</sub> Gas Dosing System with CO<sub>2</sub> tanks and vaporisers

**ASCO** provides a completely redundant system which automatically controls and regulates the CO<sub>2</sub> flow depending on a set point coming from the LCP with integrated HMI.

Depending on the condition of the storage tanks, vaporisers and the dosing systems, the system will detect and decide what parts need to take over the load to guarantee a continuous CO<sub>2</sub> injection into the side stream water. All operating conditions and status information are displayed on the touch panel and are available as data bloc for customers main control.

## Redundant ASCO CO<sub>2</sub> Gas Dosing System: Standard scope of supply

**ASCO** supplies a fully preinstalled and pretested system consisting of:

- 2 x **ASCO** CO<sub>2</sub> Gas Dosing System lines consisting of
  - filtration unit
  - flow regulating valve
  - automatic shut off valve
  - pressure reducing valve
  - manual shut off valve
  - safety valves
  - discharge valve
  - all mounted on a stainless steel base frame
- 2 x CO<sub>2</sub> flowmeters including digital display
- 1 x control cabinet (PLC)
- 2 x CO<sub>2</sub> storage tanks (capacity has to be specified at time of order)
- 2 x atmospheric CO<sub>2</sub> vaporisers (capacity has to be specified at time of order)
- 1 x static mixer or gas dispersion system (capacity has to be specified at time of order)
- 1 x automatic change over system

## Pos. 001

### CO<sub>2</sub> Gas Dosing System 5-50 kg/h (11-110 lb/h) (single line)

part no. 900135

- 1 × ASCO CO<sub>2</sub> Gas Dosing System consisting of
  - filtration unit
  - flow regulating valve
  - automatic shut off valve
  - pressure reducing valve
  - manual shut off valve
  - safety valves
  - discharge valve
  - control cabinet, prewired
  - all mounted on a stainless steel base frame
- 1 × CO<sub>2</sub> flowmeter including digital display



For a running ASCO CO<sub>2</sub> Gas Dosing System following equipment is necessary:

- 1 × CO<sub>2</sub> storage tank (capacity has to be specified at time of order)
- 1 × atmospheric CO<sub>2</sub> vaporiser (capacity has to be specified at time of order)
- 1 × static mixer or gas dispersion system (capacity has to be specified at time of order)

## Pos. 002

### CO<sub>2</sub> Gas Dosing System 30-300 kg/h (66-660 lb/h) (single line)

part no. 900136

- 1 × ASCO CO<sub>2</sub> Gas Dosing System consisting of
  - filtration unit
  - flow regulating valve
  - automatic shut off valve
  - pressure reducing valve
  - manual shut off valve
  - safety valves
  - discharge valve
  - control cabinet, prewired
  - all mounted on a stainless steel base frame
- 1 × CO<sub>2</sub> flowmeter including digital display



For a running ASCO CO<sub>2</sub> Gas Dosing System following equipment is necessary:

- 1 × CO<sub>2</sub> storage tank (capacity has to be specified at time of order)
- 1 × atmospheric CO<sub>2</sub> vaporiser (capacity has to be specified at time of order)
- 1 × static mixer or gas dispersion system (capacity has to be specified at time of order)

## Pos. 003

### CO<sub>2</sub> Gas Dosing System 100-800 kg/h (220-1'770 lb/h) (single line)

part no. 900137

- 1 × ASCO CO<sub>2</sub> Gas Dosing System consisting of
  - filtration unit
  - flow regulating valve
  - automatic shut off valve
  - pressure reducing valve
  - manual shut off valve
  - safety and discharge valves
  - control cabinet, prewired
  - all mounted on a stainless steel base frame
- 1 × CO<sub>2</sub> flowmeter including digital display



For a running ASCO CO<sub>2</sub> Gas Dosing System following equipment is necessary:

- 1 × CO<sub>2</sub> storage tank (capacity has to be specified at time of order)
- 1 × atmospheric CO<sub>2</sub> vaporiser (capacity has to be specified at time of order)
- 1 × static mixer or gas dispersion system (capacity has to be specified at time of order)

# CO<sub>2</sub> Vaporising

## Atmospheric ASCO CO<sub>2</sub> Vaporiser



The atmospheric **ASCO** CO<sub>2</sub> Vaporiser has been developed to drastically reduce CO<sub>2</sub> vaporisation costs. Available ambient air is used to achieve energy savings of over 95% compared to standard electric vaporisers. The fans are automatically controlled temperature-dependent and only work if a consumer equipment is in operation.

As each vaporiser is supplied pre-piped and pre-wired, installation can be made within minutes. Bases for floor mounting are included.

In addition to our standard models, we offer **individual solutions** of modern and easy to maintain CO<sub>2</sub> vaporisers. In accordance with your requirements, we provide you with a suitable CO<sub>2</sub> vaporiser.

### Advantages of an atmospheric ASCO CO<sub>2</sub> vaporiser:

- **NEW:** External control cabinet with 10 m connection cable for flexible installation and operation
- 25 times less energy compared with electrically heated vaporisers
- Designed for continuous and automatic operation (no attendance required)
- Built-in temperature sensors PT1000 to prevent liquid CO<sub>2</sub> from flowing through
- 2 coil system to ensure safe defrosting with built in solenoid valves
- With temperature-controlled start/stop device for intelligent power control
- Simple and fast installation, only electric power and CO<sub>2</sub> required
- Vaporisers with tubes in stainless steel or copper available

### Specifications

Vaporising capacity (approx.) from liquid CO <sub>2</sub> at 17 bar (247 psi)	length/width/height mm without control box	in/out connections outer Ø	net weight kg approx.	power consumption	max. operating pressure
200 kg/h SS (440 lb/h)	2'200 × 900 × 1'000 (87 × 35 × 39 in)	1" PN 40	243 kg (536 lb)	1.6 kW (2.1 HP)	25 bar (363 psi)
300 kg/h SS (660 lb)	3'000 × 900 × 1'000 (118 × 35 × 39 in)	1" PN 40	308 kg (679 lb)	2.4 kW (3.2 HP)	25 bar (363 psi)
500 kg/h SS (1100 lb/h)	3'000 × 900 × 1'200 (118 × 35 × 47 in)	1" PN 40	342 kg (754 lb)	2.4 kW (3.2 HP)	25 bar (363 psi)
1'000 kg/h SS (2200 lb/h)	4'200 × 1'000 × 1'450 (165 × 39 × 57 in)	1" PN 40	595 kg (1311 lb)	5.4 kW (7.2 HP)	25 bar (363 psi)

SS = with stainless steel tubes EN 1.4301 / AISI 304

Dimensions external control cabinet (L x W x H): 600 x 250 x 600 mm (24 x 9.8 x 24 in)

**Ambient air temperature: min. +10 °C, max. +45 °C**

# Atmospheric ASCO CO<sub>2</sub> Vaporisers: Description

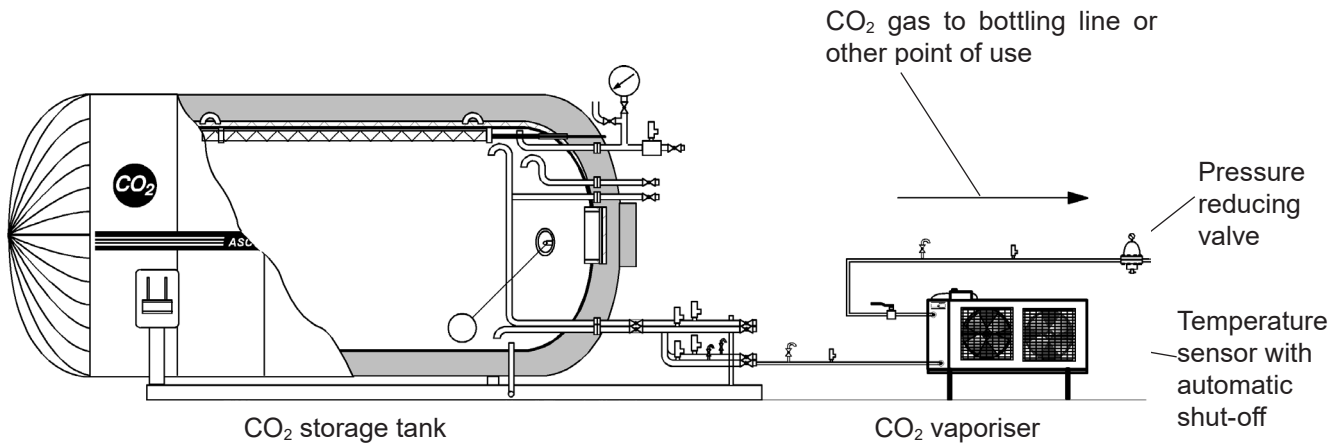

Liquid carbon dioxide is taken from a tank, completely evaporated in the vaporiser and fed to the point of use. In order to ensure safe defrosting of the vaporiser, it is equipped with two autonomous coils, which are controlled by a solenoid valve each. While one vaporiser coil is in service, the other is being defrosted. The fans only operate if a consumer equipment is obtaining CO<sub>2</sub> gas and the difference between inlet and outlet in the vaporiser reaches a defined level. This is monitored continuously.

The arrangement shown above permits operation of the vaporiser at air temperatures of max. +45 °C, at least +10 °C and, at reduced capacity as low as +5 °C in order to be able to utilise the vaporiser throughout the year, the unit should be installed inside a building away from the most inclement weather, for example in a boiler room or similar.

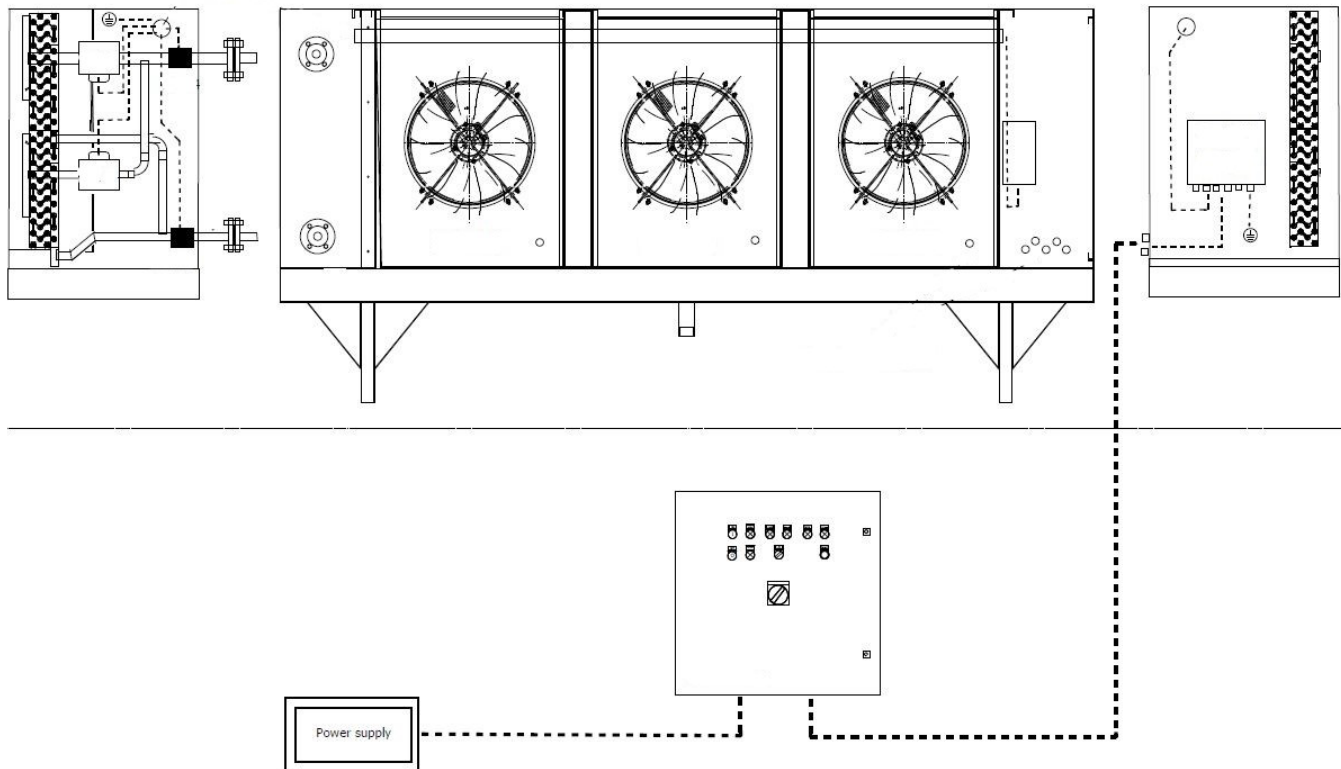

# Atmospheric ASCO CO<sub>2</sub> Vaporisers: Description and installation

## Description

**ASCO** Atmospheric CO<sub>2</sub> Vaporisers are supplied as one unit, prewired, pretested (incl. pressure test to 35.4 bar) (513.4 psi) and ready for immediate use.

They consist of a special heat exchanger unit with stainless steel tubes and aluminium fins.

Air is forced through the heat exchanger by fans. Any condensate dropping from the tubes is collected by an aluminium tray mounted on the bottom of the unit, and an outlet pipe can be connected to drain. The unit also includes solenoid valves and a complete control box. A temperature sensor is also incorporated to ensure no liquid CO<sub>2</sub> can pass through the vaporiser.

## Installation

**ASCO** Vaporisers should ideally be installed in areas such as boiler houses and similar warm rooms (max. temperature of +45 °C). External installation is only recommended where ambient air temperature is above +10 °C and max. +45 °C. They also operate at +5 °C but at reduced capacity.



Terminal box for external control cabinet

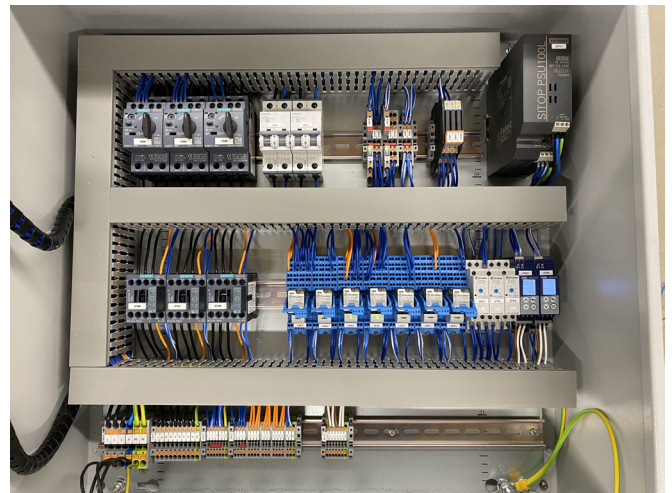

External control cabinet with 10 m connecting cable, temperature sensors and cabinet heating



1'000 kg/h (2'200 lb/h) Atmospheric ASCO CO<sub>2</sub> Vaporiser: Air intake side

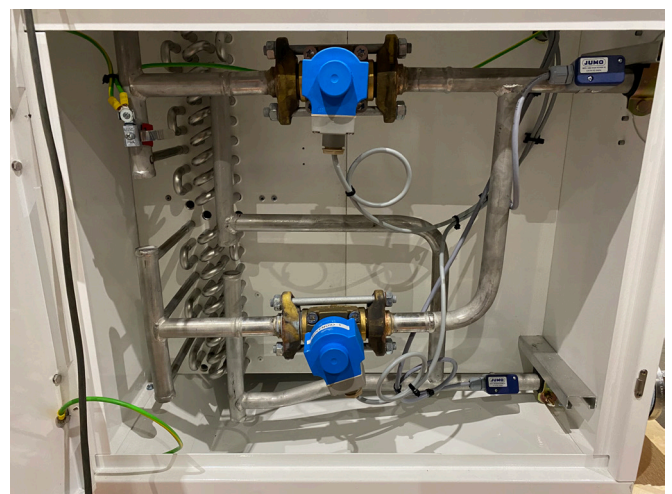

Two independent coils



## Atmospheric ASCO CO<sub>2</sub> Vaporiser: Available standard capacities

### Pos. 001

#### **200 kg/n (440 lb/h) atmospheric ASCO CO<sub>2</sub> SS Vaporiser** **200 kg/h (440 lb/h atmospheric ASCO CO<sub>2</sub> SS Vaporiser with defrost**

**part no. 901420**  
**part no. 901491**

With temperature dependent start/stop device  
Cooling circuit made of stainless steel tubes EN 1.4301 / AISI 304  
400VAC ± 5 %/50Hz/3Ph + PE +N  
(other voltages and frequencies on request)

air flow total:	3.4 m <sup>3</sup> /sec (120 ft <sup>3</sup> /sec)
coil volume:	15 l (4 gal)
net weight:	243 kg (536 lb)
fan speed:	1'330 rpm
no. of fans:	2
power cons. per fan:	0.8 kW (1.1 HP)
flange connection:	1" PN40



Minimum ambient air temperature required +10 °C, max. +45 °C

### Pos. 002

#### **300 kg/n (660 lb/h) atmospheric ASCO CO<sub>2</sub> SS Vaporiser** **300 kg/h 660 lb/h atmospheric ASCO CO<sub>2</sub> SS Vaporiser with defrost**

**part no. 901421**  
**part no. 901491**

With temperature dependent start/stop device  
Cooling circuit made of stainless steel tubes EN 1.4301 / AISI 304  
400VAC ± 5 %/50Hz/3Ph + PE +N  
(other voltages and frequencies on request)

air flow total:	5.1 m <sup>3</sup> /sec (180 ft <sup>3</sup> /sec)
coil volume:	22 l (6 gal)
net weight:	308 kg (679 lb)
fan speed:	1'330 rpm
no. of fans:	3
power cons. per fan:	0.8 kW (1.1 HP)
flange connection:	1" PN40



Minimum ambient air temperature required +10 °C, max. +45 °C

### Pos. 003

#### **500 kg/n (1100 lb/h) atmospheric ASCO CO<sub>2</sub> SS Vaporiser** **500 kg/h (1100 lb/h atmospheric ASCO CO<sub>2</sub> SS Vaporiser with defrost**

**part no. 901422**  
**part no. 901493**

With temperature dependent start/stop device  
Cooling circuit made of stainless steel tubes EN 1.4301 / AISI 304  
400VAC ± 5 %/50Hz/3Ph + PE +N  
(other voltages and frequencies on request)

air flow total:	5.1 m <sup>3</sup> /sec (180 ft <sup>3</sup> /sec)
coil volume:	41 l (11 gal)
net weight:	342 kg (754 lb)
fan speed:	1'330 rpm
no. of fans:	3
power cons. per fan:	0.8 kW (1.1 HP)
flange connection:	1" PN40



Minimum ambient air temperature required +10 °C, max. +45 °C

## Atmospheric ASCO CO<sub>2</sub> Vaporiser: Available standard capacities

Pos. 004

**1000 kg/n (2200 lb/h) atmospheric ASCO CO<sub>2</sub> SS Vaporiser**  
**1000 kg/h (2200 lb/h atmospheric ASCO CO<sub>2</sub> SS Vaporiser with defrost**

**part no. 901423**  
**part no. 901494**

With temperature dependent start/stop device  
Cooling circuit made of stainless steel tubes EN 1.4301 / AISI 304  
400VAC ± 5 %/50Hz/3Ph + PE +N  
(other voltages and frequencies on request)

air flow total:	9.9 m <sup>3</sup> /sec (350 ft <sup>3</sup> /sec)
coil volume:	78 l (21 gal)
net weight:	595 kg (1'311 lb)
fan speed:	890 rpm
no. of fans:	3
power cons. per fan:	1.8 kW (2.4 HP)
flange connection:	1" PN40



Minimum ambient air temperature required +10 °C, max. +45 °C

## Atmospheric CO<sub>2</sub> Vaporisers: Options

Pos. 001

**Dome loaded pressure reducing valve C31**

**part no. 4046817**

for gaseous and liquid CO<sub>2</sub>  
incl. repair kit (diaphragm and O-ring)



Pos. 002

**Dome loaded pressure reducing valve C2-K32**

**part no. 4046644**

for gaseous and liquid CO<sub>2</sub>  
incl. repair kit (diaphragm and O-ring)



Pos. 003

**Line safety assembly 1"- 25 bar (363 psi) welding connection**

**part no. 4046831**

Consisting of:

- stainless steel pipe 1" 300 mm (12 in)
- safety valve 25 bar (363 psi)
- vent ball valve stainless steel 1/4"



Pos. 004

### CO<sub>2</sub> flowmeter MF15

Mass flow sensor Type MF15 (fully calibrated) assembled to process pipe DN 15, PN 40 with flange connection DIN 2635.

Measuring range 0-1'000 kg/h (0- 2200lb/h) at 22 bar (319 psi)

The flow computer (on wall bracket) is equipped with digital display of current CO<sub>2</sub> flow rate in kg/h as well as totalizer and integrated keyboard.

10 meter connection cable with plug is prewired and connected.

Voltage 115 -230 V, 50/60 Hz

Accessories included:

- 2 pcs counterflange DN 15/PN40 welding (item no. 910101)
- 8 pcs screw M12 x 45, hex., inox (item no. 100020)
- 8 pcs nut M12, inox (item no. 100022)
- 2 pcs gasket DN15, 2 x 51 x 22 mm (item no. 110150)

part no. 4062504



Pos. 005

### CO<sub>2</sub> flowmeter MF25

Mass flow sensor Type MF25 (fully calibrated) assembled to process pipe DN 25, PN 40 with flange connection DIN 2635.

Measuring range 0-2'700 kg/h (0-5'940 lb/h) at 22 bar (319 psi)

The flow computer (on wall bracket) is equipped with digital display of current CO<sub>2</sub> flow rate in kg/h as well as totalizer and integrated keyboard.

10 meter connection cable with plug is prewired and connected.

Voltage 115-230 V, 50/60 Hz

Accessories included:

- 2 pcs counterflange DN 25/PN40 welding (item no. 910301)
- 8 pcs screw M12 x 45, hex., inox (item no. 100020)
- 8 pcs Nut M12, inox (item no. 100022)
- 2 pcs gasket DN25, 2 x 71 x 35 mm (0.08 x 2.80 x 1.38in) (item no. 110151)

part no. 4062505



# CO<sub>2</sub> Cylinder Filling

## ASCO CO<sub>2</sub> Cylinder Filling System LH900

part no. 901351



The **ASCO LH900 Liquid CO<sub>2</sub> Filling Pump** has been developed as a universal unit for filling high pressure CO<sub>2</sub> cylinders by weight.

Like all **ASCO** Equipment, the Cylinder Filling and Weighing System is thoroughly factory pretested before dispatch.

Thanks to the separate control unit, the pump can be placed in a different location if wanted.

### Easy operation

Via the weighing platform the exact bottle weight is determined and shown on the display. This enables the user to check whether the empty bottle weight is correct.

The selected filling weight can now be set on the display (if the same bottle size is filled several times with the same amount, it only has to be entered once).

If the desired filling weight has been reached, the solenoid valves activate the bypass. The CO<sub>2</sub> bottle can now be easily and safely uncoupled. This ensures easy and safe handling.

Specifications	LH900	LH900 TwinFill
<b>Measurements (W x D x H):</b>		
Pump stand	845 x 600 x 675 mm (33 x 24 x 27 in)	845 x 600 x 675 mm (33 x 24 x 27 in)
Control panel	505 x 500 x min. 1'035 mm (max 1'335 mm) (20 x 20 x min. 41 in) (max. 53 in)	915 x 615 x 1'210 mm (36 x 24 x 48 in)
Floor scale	635 x 575 x 2'200 mm (25 x 23 x 87 in)	630 x 590 x 2'200 mm (25 x 23 x 87 in)
<b>Weights:</b>		
Floor weighing platform	150 kg max. loading (330 lb)	150 kg max. loading (330 lb)
Pump stand	134 kg (295 lb)	134 kg (295 lb)
Control panel	37 kg with tripod (81 lb)	94 kg (207 lb)
Floor scale	55 kg (121 lb)	60 kg (132 lb)
Power consumption el. motor	4 KW	4 KW
Voltage	400 VAC ±5 %/50 Hz/3 Ph + PE + N (other voltages and frequencies on request)	400 VAC ±5 %/50 Hz/3 Ph + PE + N (other voltages and frequencies on request)
Safety valve inlet	40 bar (580 psi)	40 bar (580 psi)
Safety valve outlet	130 bar (1886 psi)	130 bar (1886 psi)

## ASCO LH900: Standard scope of supply

### ASCO CO<sub>2</sub> Cylinder Filling Pump LH900

part no. 901351

Complete CO<sub>2</sub> cylinder filling pump with a capacity of 900 kg/h (1'984 lb/h), with automatic revert and automatic shut-off.

Comprising of:

- pump with motor on base frame
- filling armature
- filling stand with weighing system
- control unit
- connection hoses between pump and control stand / control stand and filling stand 1.5 m (59 in)
- **1 x Filling head quick connector standard CO<sub>2</sub> included:**
  - W21.8 x 1/14" DIN 477 Nr.6, Type B-Thread (4043971)



### ASCO CO<sub>2</sub> Cylinder Filling Pump LH900 TwinFill

part no. 901280

Complete CO<sub>2</sub> cylinder filling pump with a capacity of 900 kg/h (1'984 lb/h), with automatic revert and automatic shut-off. As TwinFill version, the LH900 has two filling stands with integrated weighing units and an advanced filling control.

The extended filling control unit with connections for two separate filling armatures and two filling stands allows independent operation on each filling stand. Therefore a CO<sub>2</sub> bottle can be prepared on one stand while a bottle is being filled at the other stand. A parallel or alternately filling of both bottles is therefore flexibly possible.

Comprising of:

- pump with motor on base frame
- filling armature
- two filling stands with weighing system
- connection hoses between pump and control stand / control stand and filling stand 1.5 m (59 in)
- **2 x filling head quick connector standard CO<sub>2</sub> included:**
  - W21.8 x 1/14" DIN 477 Nr.6, Type B-Thread (4043971)



## ASCO LH900: Options

Pos. 001

### Adhesive label printer

part no. 4063981

For PE film labels containing

- date / time
- tare
- net and gross weight
- fillers identification

Including interface unit and connection cables. TwinFill version needs 2 printers.

Must be ordered and calibrated with the system. Subsequent installation is not possible.



## ASCO LH900: Options

Pos. 002

### Filling head quick connect standard CO<sub>2</sub>

W21.8 x 1/14" DIN 477 Nr.6, Type B thread

part no. 4043971



Pos. 003

### Filling head quick connect

CGA 320 ANG

part no. 4044082



Pos. 004

### Filling head quick connect

3/4"

part no. 4044006



Pos. 005

### Filling head quick connect

Pin

part no. 4044083



Pos. 006

### Connecting Kit LH900 / LH900 TwinFill

This set of flexible high pressure hoses provides a safe connection between the Cylinder Filling Pump and the LCO<sub>2</sub> pipework.

Length: 1.5 m (4.9 ft)

Connection inlet: 22LR-G3/4"

Connection outlet: 15LR-G1/2"

part no. 4044065



Pos. 007

### Spare parts kit

Includes a recommended selection of spare parts to ensure constant operation.

part no. 4067591



Sample image

# CO<sub>2</sub> Transfer Pumps

## ASCO CO<sub>2</sub> Transfer Pumps: Low to Low Pressure



MC-3-SS with motor on baseframe

ASCO CO<sub>2</sub> Transfer Pumps have steel housings and long life shaft seals. The pumps have hardened steel gears and thrust washers to give long service life. The mechanical seal fitted provides leak free operation.

These economical pumps need no lubrication and no day-to-day maintenance. A unique design allows parts to adjust automatically for wear. Highest efficiency is maintained for a very long time.

Installation is simple as no chain or belt drives or gear reduction motors are required. Pumps can be directly connected to standard speed low-cost electric motors. By simply changing the shaft rotation, pumps can be used to pump in or out through the same piping.

### Specifications

#### Pump capacities (approx.)

Pump model	Differential Pressure		Electrical consumption in kW	Pump capacity at 1'460 R.P.M. kg/h (50 Hz)*	Pump capacity at 1'750 R.P.M. kg/h (60 Hz)*
	bar	lb/in <sup>2</sup>			
MC-3-SS	0	0	4.0 (5.4 HP)	17'000 (37'500 lb/h)	20'000 (44'100 lb/h)
	1.4	20	4.0 (5.4 HP)	16'000 (35'300 lb/h)	19'000 (41'900 lb/h)
	3.5	50	5.5 (7.4 HP)	14'000 (30'900 lb/h)	16'000 (35'300 lb/h)

\* under ideal conditions

#### Pumps on baseframes with motors

Pump model	Motor Size		R.P.M.		Net weight	Weight packed
	50 Hz	60 Hz	50 Hz	60 Hz		
MC-3-SS	5.5 kW (7.4 HP)	6.3 kW (8.5 HP)	1'460	1'750	108 kg (238 lb)	130 kg 287 lb)
MC-3-SS movable	5.5 kW (7.4 HP)	6.3 kW (8.5 HP)	1'460	1'750	205 kg (452 lb)	248 kg (547 lb)

Voltage: 400 VAC ± 5 %/50 Hz/3 Ph + PE (other voltages and frequencies on request)  
460 VAC ± 5 %/60 Hz/3 Ph + PE (other voltages and frequencies on request)

## ASCO CO<sub>2</sub> Transfer Pumps: Low to Low Pressure

Pos. 001

### ASCO CO<sub>2</sub> Transfer Pump MC-3-SS with motor

on stainless steel baseframe

Complete heavy-duty type low to low pressure CO<sub>2</sub> transfer pump with a transfer capacity up to 17'000 kg/h (37'500 lb/h) at 1'460 rpm (50 Hz) or 20'000 kg/h (44'100 lb/h) at 1'750 rpm (60 Hz) and differential pressure of 0 barg with a 5.5 kW (7.4 HP) at 50 Hz or 6.3 kW (8.5 HP) at 60 Hz motor. The pump is designed for 2 ½ inch (63.5 mm) NPT inlet and outlet ports insides of pump. Rotation is reversible.

part no. 900092



Pos. 002

### ASCO CO<sub>2</sub> Transfer Pump MC-3-SS without motor

Complete heavy-duty type low to low pressure CO<sub>2</sub> transfer pump with a transfer capacity up to 17'000 kg/h (37'500 lb/h) at 1'460 rpm (50 Hz) or 20'000 kg/h (44'100 lb/h) at 1'750 rpm (60 Hz) and differential pressure of 0 bar with a 5.5 kW (7.4 HP) at 50 Hz or 6.3 kW (8.5 HP) at 60 Hz motor. The pump is designed for 2 ½ inch (63.5 mm) NPT inlet and outlet ports insides of pump. Rotation is reversible.

part no. 4068521



Pos. 003

### ASCO CO<sub>2</sub> Transfer Pump MC-3-SS movable, flange connection

incl. motor and stainless steel baseframe on wheels.

Complete heavy-duty type low to low pressure CO<sub>2</sub> transfer pump with a transfer capacity up to 17'000 kg/h (37'500 lb/h) at 1'460 rpm (50 Hz) or 20'000 kg/h (44'100 lb/h) at 1'750 rpm (60 Hz) and differential pressure of 0 barg with a 5.5 kW (7.4 HP) at 50 Hz or 6.3 kW (8.5 HP) at 60 Hz motor. The pump is designed for DN40 flange. Rotation is reversible.

part no. 900096



Including:

- control box
- 10 m (394 in) cable
- handrail made in stainless steel
- flanged safety device with discharge valve
- flange connection DN40 according DIN 2635



## ASCO CO<sub>2</sub> Transfer Pumps Low to Low Pressure: Options

### Pos. 001

#### Filling hose SS, DN25, 1.5" - 1.5", 5.90 m (19ft)

Stainless steel hose DN25 with total length of 5.90m. (19ft)  
With protection wire over total length.  
Both ends flat sealed with union nutg1 1/2" in brass.

part no. 4043732



### Pos. 002

#### Filling hose SS, DN40, flange DN40/PN40, 5.90 m (19ft)

Stainless steel hose DN40 with total length of 5.90m. (19ft)  
With protection wire over total length.  
Both ends flange DN40/PN40 according DIN 2635

part no. 4043736



# CO<sub>2</sub> Testing Equipment

## ASCO CO<sub>2</sub> Gas Purity Tester

part no. 900138



The **ASCO CO<sub>2</sub> Gas Purity Tester** has been designed to measure the purity of CO<sub>2</sub> up to 99.995 % in a quick, easy and reliable way. Essential for bottling plants, breweries, beverage manufacturers and industrial gas companies.

The complete kit contains all equipment for a simple, safe and fast CO<sub>2</sub> gas purity test and is complete with easy instructions (step by step pictures on a laminated A3 sheet). The **ASCO CO<sub>2</sub> Gas Purity Tester** (stainless steel) can be used either wall-mounted or free standing.

Step 1	Step 2	Step 3	Step 4	Step 5

**Purity conversion table**

Impurities %	Purity %
0.0	99.995
0.005	99.990
0.010	99.985
0.015	99.980
0.020	99.975
0.025	99.970
0.030	99.965
0.035	99.960
0.040	99.955
0.045	99.950
0.050	99.945
0.055	99.940
0.060	99.935
0.065	99.930
0.070	99.925
0.075	99.920
0.080	99.915
0.085	99.910
0.090	99.905
0.095	99.900
0.100	99.895
0.105	99.890
0.110	99.885
0.115	99.880
0.120	99.875
0.125	99.870
0.130	99.865
0.135	99.860
0.140	99.855
0.145	99.850
0.150	99.845
0.155	99.840
0.160	99.835
0.165	99.830
0.170	99.825
0.175	99.820
0.180	99.815
0.185	99.810
0.190	99.805
0.195	99.800
0.200	99.795
0.205	99.790
0.210	99.785
0.215	99.780
0.220	99.775
0.225	99.770
0.230	99.765
0.235	99.760
0.240	99.755
0.245	99.750
0.250	99.745
0.255	99.740
0.260	99.735
0.265	99.730
0.270	99.725
0.275	99.720
0.280	99.715
0.285	99.710
0.290	99.705
0.295	99.700
0.300	99.695
0.305	99.690
0.310	99.685
0.315	99.680
0.320	99.675
0.325	99.670
0.330	99.665
0.335	99.660
0.340	99.655
0.345	99.650
0.350	99.645
0.355	99.640
0.360	99.635
0.365	99.630
0.370	99.625
0.375	99.620
0.380	99.615
0.385	99.610
0.390	99.605
0.395	99.600
0.400	99.595
0.405	99.590
0.410	99.585
0.415	99.580
0.420	99.575
0.425	99.570
0.430	99.565
0.435	99.560
0.440	99.555
0.445	99.550
0.450	99.545
0.455	99.540
0.460	99.535
0.465	99.530
0.470	99.525
0.475	99.520
0.480	99.515
0.485	99.510
0.490	99.505
0.495	99.500
0.500	99.495

**CAUTION**

When handling with caustic polish or caustic soda avoid direct contact with eyes and skin (wear protective gloves and glasses). In the event of contact with eyes or skin rinse for at least 10 minutes with cold running water. Seek medical advice.

Easy step by step instruction

## ASCO CO<sub>2</sub> Gas Purity Tester: Standard scope of supply

### ASCO CO<sub>2</sub> Gas Purity Tester

part no. 900138

Complete kit comprises:

- CO<sub>2</sub> purity tester
- pair of protective gloves
- protective glasses
- two plastic containers
- flexible hose

ASCO CARBON DIOXIDE LTD | Industriestrasse 2 | CH-8590 Romanshorn | T +41 71 466 80 80 | [ascoco2.com](http://ascoco2.com)

Version 4.9 (09/23)

66

**ASCO**  
All about CO<sub>2</sub>

## Mini-Vaporiser for CO<sub>2</sub> Gas Purity Tester: Application

### CO<sub>2</sub> Mini-Vaporiser for ASCO CO<sub>2</sub> Gas Purity Tester

The mini-vaporiser vaporises liquid CO<sub>2</sub> into gaseous form. Gaseous CO<sub>2</sub> will be used to measure the CO<sub>2</sub> purity with the purity tester.

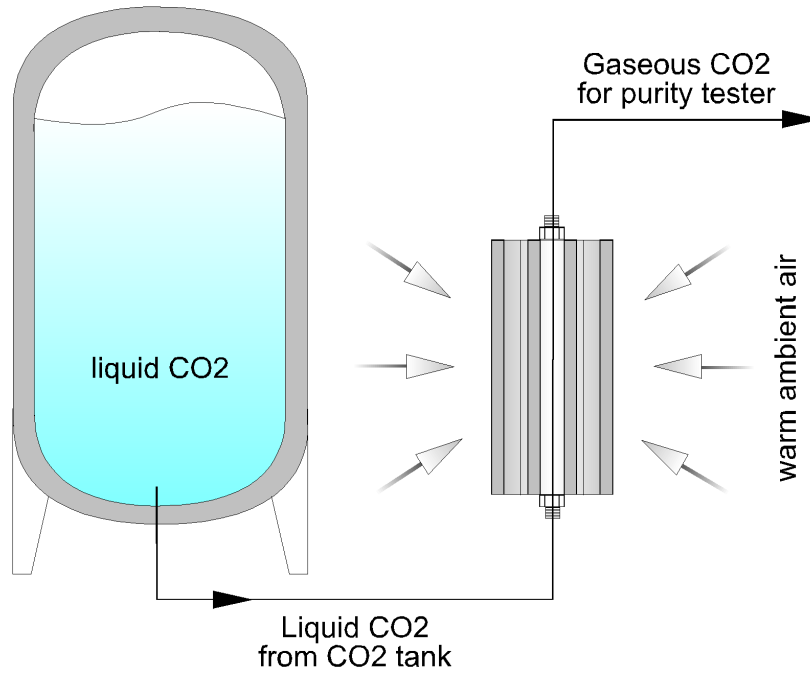

## ASCO CO<sub>2</sub> Gas Purity Tester: Options

Pos. 001

### Mini-Vaporiser for CO<sub>2</sub> Gas Purity Tester

Equipped with flow regulator  
Maximum inlet pressure 25 bar (348 psi)

Including:

- adaptor 1 1/2" (38 mm) made of stainless steel
- adaptor 1" made of stainless steel
- high pressure hose, PTFE, DN5, 6L, 2 m (6.6 ft)
- short instruction manual A3

part no. 4046324



# Testing Equipment

## ASCO CO<sub>2</sub> Carbonation Tester Type III

part no. 900900



The **ASCO** CO<sub>2</sub> Carbonation Tester is used to identify any strange odour and/or taste in CO<sub>2</sub>. With this simple, easy to use kit you can check the quality of your liquid or gaseous CO<sub>2</sub> from bulk tanks or CO<sub>2</sub> cylinders.

The set includes a CO<sub>2</sub> carbonation unit, CO<sub>2</sub> cartridge with special inner coating, adaptors made of stainless steel and emptying device for CO<sub>2</sub> cartridge and easy instructions.

Following the easy, laminated an coloured step-by-step instructions with pictures, a sample of water carbonated is tested. The carbonated water is compared for taste and smell with a non-carbonated sample of the same water.

Step 1	Step 2	Step 3	Step 4	Step 5
Arrange all parts of the complete carbonation tester.	Empty the CO <sub>2</sub> sampling cylinder completely by screwing it vertically upside down into the thread of the head (the thread must face to a right). After emptying, unscrew the cylinder.	A sample of the CO <sub>2</sub> to be tested is withdrawn from the liquid or gaseous phase of an empty tank or a cylinder by letting it flow into the CO <sub>2</sub> testing cylinder which has a special inner coating for neutral taste. The connection to the valves of the storage tank or cylinder is made with the special adaptors supplied by ASCO. Then open the outlet valve and let CO <sub>2</sub> flow into the sampling cylinder for 10 seconds. Now close the outlet valve.	Repeat steps 2 and 3 twice to ensure that no CO <sub>2</sub> from earlier tests is left in the cylinder.	Filling the carbonation bottle: Turn the flask lever to the right, to the unlocked position. The machine head will rise automatically. Return glass bottle flask to upright position, push and hold the machine head down and turn the flask lever left, to the locked position. Press rear cover, release bottom, disconnect and remove back cover. Disconnect and remove back cover. The jet nozzle can be in the edge of the bottle opening. Slowly lower the device head, making sure that the nozzle slides into the bottle opening.
Step 6	Step 7	Step 8	Step 9	
Releasing the gas cylinder: Place the glass vessel in upright position on a flat surface. Press rear cover release button downwards and remove back cover. Remove the valve seal and plastic cap from the new cylinder valve. Screw the new cylinder firmly into the cylinder holder. Do not use any tools for this. Tighten the back cover. Fill the bottle with clean, cold or bottled, uncarbonated drinking water up to the lowest mark.	Carbonation: Press the carbonating lever downwards, as shown, using firm pressure of 2 to 3 seconds. You will hear the gas entering the bottle. Release the lever after each press. 2 presses will make a standard sparkling drink.	Removing the bottle after carbonation: Turn the flask lever right to the unlocked position until the machine head starts to rise. Excess gas in the bottle will be heard escaping from the machine as you turn the lever right. The glass bottle flask forward and remove glass bottle.	Now pour the carbonated water into a clean glass and test for colour and taste. Another glass of the same uncarbonated water should be used as a control sample against which the colour and taste can be compared.	
<b>CAUTION</b> While handling liquid CO <sub>2</sub> and cylinders under pressure make sure the above mentioned steps are followed exactly. Under no circumstances disconnect the sampling cylinder while the CO <sub>2</sub> valve of the tank or cylinder is open!				

### Advantages of a ASCO CO<sub>2</sub> Carbonation Tester:

- easy handling
- no calibration required
- ready for immediate use
- quick and cheap testing method
- for gaseous and liquid CO<sub>2</sub>

Easy step by step instruction

## ASCO CO<sub>2</sub> Carbonation Tester: Standard scope of supply

### ASCO CO<sub>2</sub> Carbonation Tester

part no. 900900

Complete kit comprises:

- CO<sub>2</sub> aluminium cylinder with special hard inner coating for neutral taste
- unit to carbonate water
- 2 glass bottles 0.615l
- device to empty CO<sub>2</sub> cylinder
- four adaptors:
  - 1 1/2" female
  - 1" female
  - 1/4" male
  - CO<sub>2</sub> female (W21.8 x 1/14")



# Testing Equipment

## ASCO CO<sub>2</sub> Dew Point Tester

part no. 4046255



The **ASCO CO<sub>2</sub> Dew Point Tester** reliably indicates the dew point (moisture content) of your CO<sub>2</sub>.

This equipment makes it easy to measure the dew point of liquid and gaseous CO<sub>2</sub>. A laminated, illustrated step-by-step short instruction sheet in A3 format and a detailed instruction manual are supplied with each tester. The **ASCO CO<sub>2</sub> Dew Point Tester** (stainless steel) can be used either wall-mounted or free-standing.

### Advantages of a CO<sub>2</sub> Dew Point Tester:

- easy handling
- no calibration required
- ready for immediate use
- for gaseous and liquid CO<sub>2</sub>

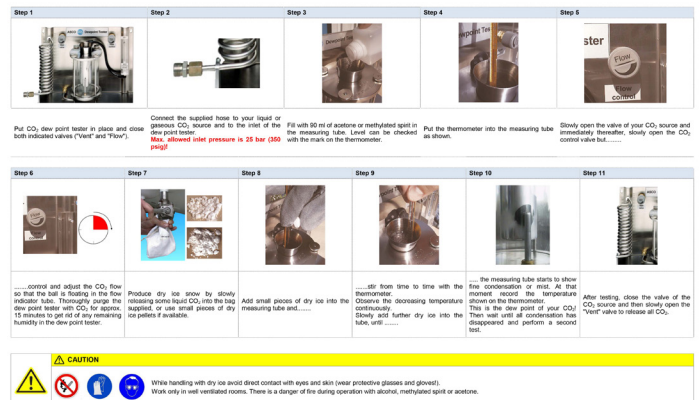

Easy step by step instruction

## ASCO CO<sub>2</sub> Dew Point Tester: Standard scope of supply

### ASCO CO<sub>2</sub> Dew Point Tester

part no. 4046255

Complete kit comprises:

- complete dew point tester
- thermometer
- pair of protective gloves
- protective glasses
- dry ice snow bag
- high pressure hose



# CO<sub>2</sub> Equipment

## ASCO CO<sub>2</sub> Flowmeter



The **ASCO** CO<sub>2</sub> Flowmeter has been developed to accurately measure CO<sub>2</sub> gas flow in closed pipes.

The power unit, which supplies 230 V, operates a microprocessor controlled flow computer and one sensor.

The **ASCO** CO<sub>2</sub> Flowmeter is a complete system which is supplied fully calibrated and wired and therefore very easy to install.

### Features

- easy to install
- very accurate (0.1 %)
- single point measurement
- no pressure and temperature compensation required
- no moving parts
- direct mass flow reading
- tension free contact alarm and fault status output
- self-testing electronics

Accurate CO<sub>2</sub> measurement can help to find CO<sub>2</sub> leaks and to achieve optimum CO<sub>2</sub> yields. Practical tests have shown that by using an **ASCO** CO<sub>2</sub> Flowmeter, CO<sub>2</sub> savings of up to 30 % can be achieved.

### Specifications

	<b>Type MF15</b> part no. 4062504	<b>Type MF25</b> part no. 4062505
Measuring range:	1'000 kg/h (2'200 lb/h) at 22 bar (319 psi)	2'700 kg/h (5'940 lb/h) at 22 bar (319 psi)
Nominal pipe diameter:	15 mm (0.6")	25 mm (1")
Connections (flanges DIN 2635, PN 40):	DN 15 (1/2")	DN 25 (1")
Max. working pressure:	40 bar (580 psi) (tested to 60 bar) (870 psi)	40 bar (580 psi) (tested to 60 bar) (870 psi)
Medium temperature:	-50 to +180 °C	-50 to +180 °C
Permissible ambient temperature:	-20 to +55 °C	-20 to +55 °C
Accuracy:	0.1 % of rate (above 10 kg/h) (22 lb/h)	0.1 % of rate (above 10 kg/h) (22 lb/h)
Repeatability:	± 0.5 % of rate	± 0.5 % of rate
Materials of construction:	AISI 316L/1.4435/1.4404	AISI 316L/1.4435/1.4404
Weight approx:		
- sensor	6 kg (13 lb)	10 kg (22 lb)
- controller	5 kg (11 lb)	5 kg (11 lb)

## ASCO CO<sub>2</sub>-Flowmeter MF15: Standard scope of supply

### ASCO CO<sub>2</sub> Flowmeter MF15

Mass flow sensor Type MF15 (fully calibrated) assembled to process pipe DN 15, PN 40 with flange connection DIN 2635.

Measuring range 0 - 1'000 kg/h ( 0 - 2200 lb/h) at 22 bar (319 psi)

The flow computer (on wall bracket) is equipped with digital display of current CO<sub>2</sub> flow rate in kg/h as well as totalizer and integrated keyboard.

10 meter connection cable with plug is prewired and connected.

Voltage 115 -230 V, 50/60 Hz

part no. 4062504



Accessories included:

- 2 pcs counterflange DN 15/PN40 welding (item no. 910101)
- 8 pcs screw M12 x 45, hex., inox (item no. 100020)
- 8 pcs Nut M12, inox (item no. 100022)
- 2 pcs gasket DN15, 2 x 51 x 22mm (item no. 110150)

## ASCO CO<sub>2</sub>-Flowmeter MF25: Standard scope of supply

### ASCO CO<sub>2</sub> Flowmeter MF25

Mass flow sensor Type MF25 (fully calibrated) assembled to process pipe DN 25, PN 40 with flange connection DIN 2635.

Measuring range 0 -2'700 kg/h (0 -5'940 lb/h) at 22 bar (319 psi)

The flow computer (on wall bracket) is equipped with digital display of current CO<sub>2</sub> flow rate in kg/h as well as totalizer and integrated keyboard.

10 meter connection cable with plug is prewired and connected.

Voltage 115-230 V, 50/60 Hz

part no. 4062505



Accessories included:

- 2 pcs counterflange DN 25/PN40 welding (item no. 910301)
- 8 pcs screw M12 x 45, hex., inox (item no. 100020)
- 8 pcs Nut M12, inox (item no. 100022)
- 2 pcs gasket DN25, 2 x 71 x 35mm (0.08 x 2.80 x 1.4 in) (item no. 110151)

# CO<sub>2</sub> Equipment

## ASCO CO<sub>2</sub> Cylinder Valve

part no. 4046736



ASCO CO<sub>2</sub> Cylinder Valve are used on standard CO<sub>2</sub> cylinders to regulate the CO<sub>2</sub> supply.

The CO<sub>2</sub> valve consists of an aluminium hand wheel and brass body. The threading is conical for safe and proper sealing.

All ASCO CO<sub>2</sub> Cylinder Valves are equipped with bursting disc for maximum safety.

### Specifications

A	=	W 21,8 x 1/14" to DIN 477
B	=	Ø 8 mm (0.3 in)
C	=	28.8 x 1/14"
D	=	Ø 7 mm (0.3 in)
E	=	112 mm (4.4 in)
F	=	47 mm (1.9 in)
G	=	M10 x 0.75 mm (0.03 in)
Bursting disc	=	190 bar (2756 psi)
Handwheel	=	Aluminium
Valve Body	=	Brass
Weight approx.	=	520 g (1.45 lb)

Valves to other specifications on request!

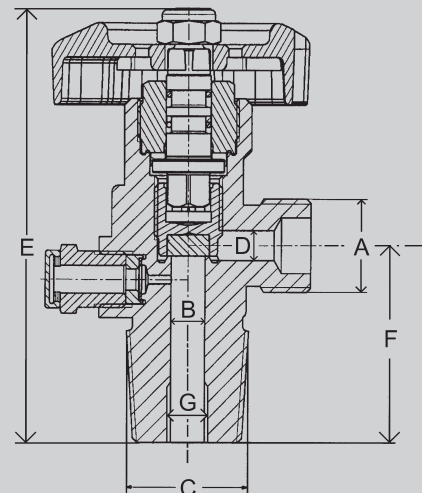

## ASCO CO<sub>2</sub> Cylinder Valve: Standard scope of supply

### ASCO CO<sub>2</sub> Cylinder Valve

in brass, with:

- O-Ring
- max. operating pressure 200 bar (2'900 psi)
- inner thread for syphon tube
- aluminium hand wheel
- bursting safety disc (bursting pressure 190 bar) (2'755 psi)

part no. 4046736





# CO<sub>2</sub> Equipment

## ASCO Line Safety Assembly

part no. 4046831

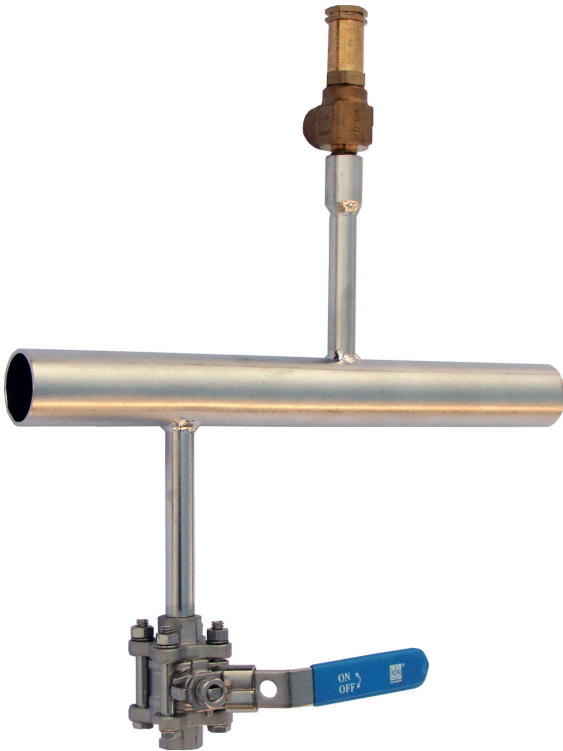

Whenever an **ASCO** CO<sub>2</sub> Vaporiser or Tank is installed, a line safety assembly must be added in case liquid CO<sub>2</sub> is trapped between 2 valves in the pipeline. If this happens the safety valve will activate to avoid damaging the pipework.

## ASCO Line Safety Assembly: Standard scope of supply

### Pos. 001

#### Line safety assembly 1" -25 bar (363 psi) welding connection

part no. 4046831

Consisting of:

- stainless steel pipe 1" 300 mm (11.8 in)
- safety valve 25 bar (363 psi)
- vent ball valve stainless steel 1/4"



### Pos. 002

#### Line safety assembly 1" -30 bar (435 psi)

part no. 4046828

Consisting of:

- stainless steel pipe 1" 250 mm (9.8 in)
- one side welding connection
- other side tank connection, silver solder
- raiser tube for safety valve
- safety valve 30 bar (435 psi)
- vent ball valve stainless steel 1/4"

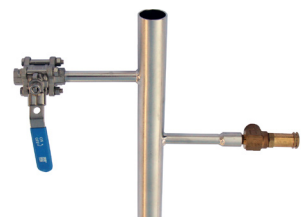

# CO<sub>2</sub> Equipment

## ASCO CO<sub>2</sub> Pressure Reducing Valve



C31



C2-K32

The ideal and reliable high-flow CO<sub>2</sub> pressure reducing valve for use with CO<sub>2</sub> gas or liquid.

### Advantages of a CO<sub>2</sub> pressure reducing valve:

- Constructed in brass (C31) and meehanite (C2-K32) with stainless steel trim
- Abrasion and dirt resistant rubber valve seats
- Dome loading either from inlet line or separate gas supply
- Stable and noiseless operation
- Positive gas-tight shut-off
- High-flow contoured passages

### Specifications

	Type C31 part no. 4046817	Type C2-K32 part no. 4046644
CO <sub>2</sub> gas output per hour calculated at inlet pressure at 18 bar (261 psi)		
• outlet at 5 bar (73 psi)	621 kg/h (1'369 lb/h)	3'142 kg/h (6'927 lb/h)
• outlet at 8 bar (116 psi)	621 kg/h (1'369 lb/h)	3'142 kg/h (6'927 lb/h)
• outlet at 10 bar (145 psi)	615 kg/h (1'356 lb/h)	3'114 kg/h (6'865 lb/h)
Connection	R 1"	R 2"
Weight approx.	6 kg (13.2 lb)	19 kg (41.9 lb)
Maximum inlet pressure	100 bar (1450 psi)	70 bar (1015 psi)
Maximum outlet pressure	0.5 - 70 bar (7-1015 psi)	0.5 - 70 bar (7-1015 psi)

## ASCO CO<sub>2</sub> Pressure Reducing Valve: Dimensions

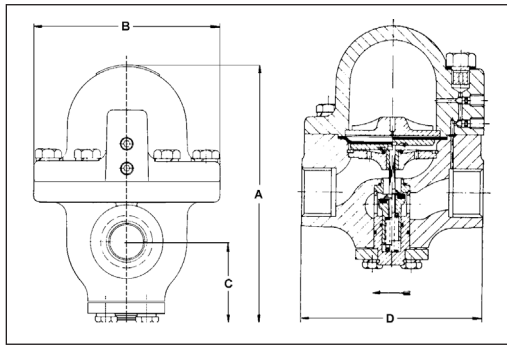

C31

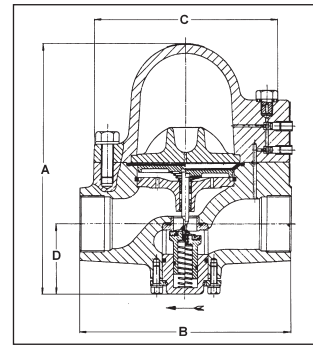

C2-K32

	Type C31 part no. 4046817	Type C2-K32 part no. 4046644
A	170 mm (6.7 in)	263 mm (10.4 in)
B	126 mm dia. (5 in)	227 mm (9 in)
C	52 mm (2 in)	197 mm dia. (7.8 in)
D	127 mm (5 in)	75 mm (3 in)

## ASCO CO<sub>2</sub> Pressure Reducing Valve C31: Standard scope of supply

### ASCO CO<sub>2</sub> Pressure Reducing Valve C31 (Dome Loaded)

part no. 4046817

for gaseous or liquid CO<sub>2</sub>  
incl. repair kit (diaphragm and O-ring)



## ASCO CO<sub>2</sub> Pressure Reducing Valve C2-K32: Standard scope of supply

### ASCO CO<sub>2</sub> Pressure Reducing Valve C2-K32 (Dome Loaded)

part no. 4046644

for gaseous or liquid CO<sub>2</sub>  
incl. repair kit (diaphragm and O-ring)



## ASCO CO<sub>2</sub> Gas Detectors



**ASCO** CO<sub>2</sub> Gas Detectors are used to protect personnel wherever CO<sub>2</sub> gas or dry ice is used in closed areas, for example during dry ice blasting or when producing dry ice. **ASCO** offers wall-mounted solutions for area monitoring and portable devices for personal protection.

**ASCO** CO<sub>2</sub> Gas Detectors ensure continuous and automatic CO<sub>2</sub> content measuring in the ambient air using infrared absorption measuring (NDIR). This technology is very trouble-resistant to temperature variations or air draughts and therefore measures very accurately. The CO<sub>2</sub> gas detectors are very simple to handle and all components are built splash proof.

## ASCO CO<sub>2</sub> Gas Detector AGS for area monitoring (wall-mounted)

### ASCO CO<sub>2</sub>-Gas-Detector AGS Station

Stationary CO<sub>2</sub> Gas-Detector AGS for CO<sub>2</sub> content monitoring in rooms, consisting of a display and sensor unit.

Characteristics:

- Alarm signals acoustically and visually at 3 limit values
- Calibration with Nitrogen N<sub>2</sub>
- Versatile connection and integration options
- IP54 housing classified for dust and splash protection
- Integrated emergency power battery

part no. 901261



### Specifications Detector

Dimensions/weight:	140 x 90 x 48 mm (5.5 x 3.5 x 1.9 in) / approx. 0.9 kg (1.9 lb)
Material box:	plastic (IP54)
Resolution:	0.1 Vol. % CO <sub>2</sub> (10ppm bei 0~10,000ppm/100ppm bei 10,001~50,000ppm)
Voltage/ Power supply:	
DC:	9 - 32 VDC (12 – 32 VDC recommended), 2 A
AC adapter:	Input: 100 – 240 VAC, 50/60 Hz, 0,6 A Output: 12 VDC, 2000 mA
Max. power consumption:	approx. 2 W
Relay preliminary alarm/alarm:	below 2 A at 30 VDC or 250 VAC, SPDT
Analog output signal:	4-20 mA

### Specifications Sensor

Size/weight:	170 x 126 x 69 mm (6.7 x 5 x 2.7 in) / approx. 0.5 kg (1 lb)
Material box:	plastic (IP54)
Gas entry:	diffusion
Measuring method:	nondispersive infrared measurement (NDIR)
Measuring range:	0-5 Vol. % CO <sub>2</sub> (0 - 50.000 ppm)
Accuracy:	0.1 Vol. % CO <sub>2</sub> (+- 100 ppm oder +- 5%)
Operating temperature:	0 to +50 °C

## ASCO CO<sub>2</sub> Gas Detector AGP

Portable CO<sub>2</sub> Gas Detector to protect employees in areas where carbon dioxide buildup may cause personal harm.

### Features:

- Audible, visual strobe and vibrating alarms
- Man down alarm
- Rechargeable Li-ion battery
- Two calibration methods
- Heavy duty metal clip

part no. 901260



## Specifications

Alarm settings:	3 thresholds
Alarm signals:	audible, visual, vibrating
Dimensions:	98 x 50 x 42 mm (3.9 x 2.0 x 1.7 in)
Weight:	approx. 0.14 kg (0.3 lb)
Material:	plastic material (IP54)
Power:	4.2V, 1500mAh Li-ion battery rechargeable (USB cable included)
Operating conditions:	0° - 50° C
Warm up time:	approx. 5 sec.
Resolution:	1 ppm; 0.01 vol % CO <sub>2</sub>
Accuracy:	±40 ppm / ±3 %
Gas entry:	diffusion
Measuring method:	nondispersive infrared measurement (NDIR)
Measuring range:	0-5 vol % CO <sub>2</sub>
Calibration interval:	1 year
Calibration method:	Nitrogen or ambient air

# Dry Ice Storage

## ASCO Dry Ice Box AT126

part no. 4063246



The **ASCO** Dry Ice Box AT126 is especially designed and developed for the storage of dry ice and offers good isolation. The material used on this formstable and lightweight box makes it robust and shock resistant for frequent use.

Thanks to the clever design with integrated bases no pallet is needed to stack the dry ice boxes.

### Specifications

	AT126
Material:	expanded PP (Polypropylene)
Inner dimensions (L×W×H):	663×456×420 mm (26 x 18 x 17 in)
Outer dimensions (L×W×H):	803×596×671 mm (32 x 23 x 26 in)
Weight empty:	10.3 kg (22.7 lb)
Cubic capacity:	approx. <b>126 litres (4.5 ft<sup>3</sup>)</b>
Average storage loss:	approx. 7.4 % / day
Capacity with pellets:	approx. 100 kg (220.6 lb)
Capacity with blocks:	approx. 155 kg (341.7 lb)

## Dry Ice Storage: Options

Pos. 001

### Dry ice shovel big

For optimum filling of the 3 mm (1/8 in) dry ice pellets into the ASCO Dry Ice Blasting equipment

Dimensions (L x W): 270 x 180 mm (11 x 7 in)

Wooden handle: 110 mm (4 in)

Material: wood / aluminium

part no. 4046629



# Dry Ice Storage

## ASCO Dry Ice Container AT240W

part no. 4063652



The **ASCO** Dry Ice Container AT240W made of polyethylene with foam filled cavities provides excellent insulation values.

The container has a lid with integrated hinges and a simple but very stable closing mechanism. The locking made of stainless steel is adjustable and offers the possibility to seal the container.

The integrated securable wheels (2 fixed wheels, 2 castor wheels) allow easy handling wherever the container is needed. The wheels are within the scope of supply, but are not mounted at delivery.

### Specifications

### AT240W

Material:	Polyethylene with integrated foam as isolation
Inner dimensions (L x W x H):	940 x 500 x 530 mm (37 x 20 x 21 in)
Outer dimensions (L x W x H):	1'150 x 705 x 1'020 mm (45 x 28 x 40 in)
Working height (with open lid):	925 mm (36 in)
Weight empty:	54 kg (119 lb)
Locks:	Stainless steel
Cubic capacity:	approx. <b>240 litres (8.5 ft<sup>3</sup>)</b>
Average storage loss:	approx. 4.0 % / day
Capacity with pellets:	approx. 188 kg (414 lb)
Capacity with blocks:	approx. 280 kg (617 lb)

## Dry Ice Storage: Options

Pos. 001

### Dry ice shovel big

For optimum filling of the 3 mm (1/8 in) dry ice pellets into the ASCO Dry Ice Blasting equipment

Dimensions (L x W): 270 x 180 mm (11 x 7 in)

Wooden handle: 110 mm (4 in)

Material: wood / aluminium

part no. 4046629



# Dry Ice Storage

## ASCO Dry Ice Container AT440

part no. 4064262



The specially developed foam-in-place urethane insulation of the **ASCO** Dry Ice Container AT440 provides outstanding temperature control and long lasting durability.

The special design of the cover and the bottom allows for easy stacking of the containers. Innovative gasket design between lid and container locks cold in. Furthermore, the reduced rib and label area profiles allow for increased insulation, yielding much lower sublimation rates.

The **ASCO** Dry Ice Container AT440 corresponds to Euro pallet designed to a 1'200x800 mm (47x32 in) footprint and therefore can be used ideally for storage and transport purposes.

### Specifications

### AT440

Material:	Polyethylene with integrated foam as isolation
Inner dimensions (L x W x H):	1'025 x 650 x 655 mm (40 x 26 x 26 in)
Outer dimensions (L x W x H):	1'175 x 800 x 990 mm (46 x 32 x 39 in)
Working height (with open lid):	920 mm (36 in)
Weight empty:	60 kg (132 lb)
Cubic capacity:	<b>approx. 440 litres (15.54 ft<sup>3</sup>)</b>
Average storage loss:	approx. 4.1 % / day
Capacity with pellets:	approx. 344 kg (758 lb)
Capacity with blocks:	approx. 512 kg (1'129 lb)

## Dry Ice Storage: Options

Pos. 001

### Dry ice shovel big

For optimum filling of the 3 mm (1/8 in) dry ice pellets into the ASCO Dry Ice Blasting equipment

Dimensions (L x W): 270 x 180 mm (11 x 7 in)  
Wooden handle: 110 mm (4 in)  
Material: wood / aluminium

part no. 4046629





# Dry Ice Production

## ASCO Dry Ice Pelletizer P15i-D3

part no. 901310



The **ASCO** Dry Ice Pelletizer P15i is a compact and powerful dry ice machine from our **i-Series line**. Having a production capacity of 150 kg/h (331 lb/h) it meets the demands for higher dry ice quantities plus quality and flexibility in the daily working process.

As a model of **ASCO's** i-Series, it is equipped with state-of-the-art remote control devices and thus is ready for a wide range of services in the areas of **Remote Access, Remote Data, Remote Management**. Whether for fast and efficient trouble shooting and maintenance or for gathering production and performance data - the **ASCO** i-Series offers a wide range of possibilities to **link Industry 4.0 with dry ice production**.

The **ASCO** Dry Ice Pelletizer P15i is driven by a powerful hydraulic unit featuring instant push button start. All functions are controlled by a Siemens PLC with touch screen. A fully automatic control of oil temperature and dry ice snowing process guarantees continuous dry ice production without any supervision right from pushing the start button.

To maximise the CO<sub>2</sub> to dry ice conversion ratio the dry ice pelletizer can be connected to an **ASCO** Revert Gas Recovery System.

### Benefits of an in-house dry ice production:

- more efficient cleaning results, because the fresher the dry ice, the more efficient the cleaning
- shorter production stops
- reduction of dry ice lost due to sublimation
- decreased logistics expense connected with purchasing and disposing of dry ice

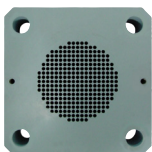

### Extruder plate for 3 mm (1/8 ") pellets

The dry ice pelletizer P15i-D3 is standardly equipped with an extruder plate for pellets with a diameter of 3 mm (1/8 ").

### Specifications

Production capacity:	150 kg/h (331 lb/h) ± 5% at 16-20 bar (232 - 290 psi) CO <sub>2</sub> inlet pressure
Voltage:	400 VAC ± 5 %/50 Hz/3 Ph + PE (other voltages and frequencies on request)
Max. power consumption:	5.6 kW (7.5 HP)
Dimensions (L x W x H):	1'560 x 800 x 1'450 mm (61 x 32 x 57 in)
Weight net:	440 kg (970 lb) (without hydraulic oil) 500 kg (1'100 lb) (with hydraulic oil)
Weight packed:	approx. 550 kg (1'213 lb) (without hydraulic oil)
CO <sub>2</sub> inlet connection:	1" BSP female
CO <sub>2</sub> source:	CO <sub>2</sub> storage tank, liquid phase (16-20 bar) (232 - 290 psi)
Connectivity and remote access:	LAN, Ethernet, WiFi, 3G (other data services on demand)



## ASCO Dry Ice Pelletizer P15i-D3: Function and applications

The **ASCO** Dry Ice Pelletizer P15i requires a liquid CO<sub>2</sub> supply (pressure 16-20 bar) (232-290 psi) and power supply of 400 V / 50 Hz / 3 Ph + PE (other voltages available on request). The machine features instant push button start and all functions are controlled by an inbuilt PLC. Dry ice snow is produced in the snowing chamber, pressed and then extruded by a powerful hydraulic unit. Hard, dense dry ice pellets are produced shortly after pushing the start button.

To ensure continuous, reliable operation of the pelletizer, oil temperature, oil level, cycle time, injection time, operation hours, due date of service, motor overload, amount dry ice produced since last start, CO<sub>2</sub> inlet pressure and hydraulic pressure are all monitored and displayed on the touch screen of the P15i's PLC.

### Options

The **ASCO** Dry Ice Pelletizer P15i is standardly equipped with an extruder plate for the production of pellets with a diameter of 3 mm (1/8 "). Such pellets are used especially for dry ice blasting purposes. Optional extruder plates for the production of 10 mm (3/8 ") and 16 mm (5/8 ") pellets (for cooling purposes) are also available. Other dimensions are available on request. The P15(i), however, can also be delivered standardly equipped with such an extruder plate.

<b>Pellet size</b>	 3mm (1/8 ")	 10mm (3/8 ")	 16mm (5/8 ")
<b>Operating range</b>	Dry ice blasting	Cooling purposes	Cooling purposes

## ASCO Dry Ice Pelletizer P15i-D3: Key features

- **PLC SIEMENS-S7-1200** - controls the complete process, injection and hydraulic
- **Siemens touch screen 7"** - with different access levels and information regarding the started production
- **Remote control devices** - offers a wide range of possibilities to link Industry 4.0 with dry ice production
- **Independent performance** - very constant production, independent of pressure and temperature in the range of 16 - 20 bar (232 -290 psi).
- **Integrated production control system** - definition and supervision of production quantity
- **High process reliability** - optimised process monitoring provides optimal performance and increases process reliability
- **Easy maintenance / optimal service planning** - comprehensive error history, indication on touch screen when next service is due
- **Minimum floor space for high production performance**

## ASCO Dry Ice Pelletizer P15i-D3: Standard scope of delivery

### Extruder plate for 3 mm (1/8 ") pellets

Pellets for **blasting purposes**

part no. 4044250

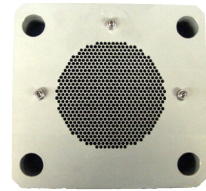

### i-Series

Enables remote access and data services via LAN, Ethernet, WiFi, 3G (other data services on demand)  
Discounts, features, period of validity and monthly subscription fees depend on the selected i-Series service contract.



## ASCO Dry Ice Pelletizer P15i-D3: Options

Pos. 001

### Extruder plate for 10 mm (3/8 ") pellets

Pellets for **cooling purposes**

part no. 4044255

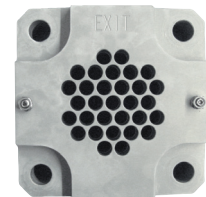

Pos. 002

### Extruder plate for 16 mm (5/8 ") pellets

Pellets for **cooling purposes**

part no. 4044253



Pos. 003

### Spare parts kit

Includes a recommended selection of spare parts to ensure constant operation.

part no. 4068376



Sample image

Pos. 004

### Connecting Kit 1" A220P/A240P/P15i/P28i

For flexible connection.

Length: 1.5 m

part no. 4044246



# Dry Ice Production

## ASCO Dry Ice Pelletizer P28i-D3

part no. 900760



The **ASCO** Dry Ice Pelletizer P28i is a compact and powerful dry ice machine from our **i-Series** line. Having a production capacity of 280 kg/h (617 lb/h) it meets the demands for higher dry ice quantities plus quality and flexibility in the daily working process.

As a model of **ASCO's** i-Series, it is equipped with state-of-the-art remote control devices and thus is ready for a wide range of services in the areas of **Remote Access, Remote Data, Remote Management.**

Be it for fast and efficient trouble shooting and maintenance or for gathering production and performance data - the **ASCO** i-Series offers a wide range of possibilities to **link Industry 4.0 with dry ice production.**

The **ASCO** Dry Ice Pelletizer P28i is driven by a powerful hydraulic unit featuring instant push button start. All functions are controlled by a Siemens PLC with touch screen. A fully automatic control of oil temperature and dry ice snowing process guarantees continuous dry ice production without any supervision right from pushing the start button.

To maximise the CO<sub>2</sub> to dry ice conversion ratio the dry ice pelletizer can be connected to an **ASCO** Revert Gas Recovery System.

### Benefits of an in-house dry ice production:

- if for dry ice blasting: more efficient cleaning results, because: the fresher the dry ice, the more efficient the cleaning
- shorter production stops
- reduction of dry ice lost due to sublimation
- decreased logistics expense connected with purchasing and disposing of dry ice

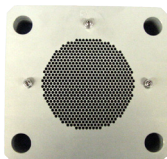

### Extruder plate for 3 mm (1/8 ") pellets

The ASCO Dry Ice Pelletizer P28i is standardly equipped with an extruder plate for the production of pellets with a diameter of 3 mm (1/8 ").

### Specifications

Production capacity:	280 kg/h (617 lb/h) ± 5% at 16 - 20 bar (232-290 psi) CO <sub>2</sub> inlet pressure
Voltage:	400 VAC ± 5 %/50 Hz/3 Ph + PE (other voltages and frequencies on request)
Max. power consumption:	5.6 kW (7.5 HP)
Dimensions (L x W x H):	1'560 x 800 x 1'450 mm (61 x 32 x 57 in)
Weight net:	440 kg (970 lb) (without hydraulic oil) 500 kg (1'100 lb) (with hydraulic oil)
Weight packed:	approx. 550 kg (1'213 lb) (without hydraulic oil)
CO <sub>2</sub> inlet connection:	1" BSP female
CO <sub>2</sub> source:	CO <sub>2</sub> storage tank, liquid phase (16-20 bar) (232-290 psi)
Connectivity and remote access:	LAN, Ethernet, WiFi, 3G (other data services on demand)



## ASCO Dry Ice Pelletizer P28i-D3: Function and applications

The **ASCO** Dry Ice Pelletizer P28i requires a liquid CO<sub>2</sub> supply (pressure 16-20 bar) (232-290 psi) and power supply of 400 V / 50 Hz / 3 Ph + PE (other voltages available on request). The machine features instant push button start and all functions are controlled by an inbuilt PLC. Dry ice snow is produced in the snowing chamber, pressed and then extruded by a powerful hydraulic unit. Hard, dense dry ice pellets are produced shortly after pushing the start button.

To ensure continuous, reliable operation of the pelletizer, oil temperature, oil level, cycle time, injection time, operation hours, due date of service, motor overload, amount dry ice produced since last start, CO<sub>2</sub> inlet pressure and hydraulic pressure are all monitored and displayed on the touch screen of the P28i's PLC.

### Options

The **ASCO** Dry Ice Pelletizer P28i is standardly equipped with an extruder plate for the production of pellets with a diameter of 3mm (1/8 "). Such pellets are used especially for dry ice blasting purposes. Optional extruder plates for the production of 10mm (3/8 ") and 16mm (5/8 ") pellets (for cooling purposes) are also available. The P28i, however, can also be delivered standardly equipped with such an extruder plate.

<b>Pellet size</b>	 3mm (1/8 ")	 10mm (3/8 ")	 16mm (5/8 ")
<b>Operating range</b>	Dry ice blasting	Cooling purposes	Cooling purposes

## ASCO Dry Ice Pelletizer P28i-D3: Key features

- **PLC SIEMENS-S7-1200** - controls the complete process, injection and hydraulic
- **Siemens touch screen 7"** - with different access levels and information regarding the started production
- **Remote control devices** - offers a wide range of possibilities to link Industry 4.0 with dry ice production
- **Independent performance** - very constant production, independent of pressure and temperature in the range of 15-20 bar (218 -290 psi).
- **Integrated production control system** - definition and supervision of production quantity
- **High process reliability** - optimised process monitoring provides optimal performance and increases process reliability
- **Easy maintenance / optimal service planning** - comprehensive error history, indication on touch screen when next service is due
- **Minimum floor space for high production performance**

## ASCO Dry Ice Pelletizer P28i-D3: Standard scope of delivery

### Extruder plate for 3 mm (1/8 ") pellets

Pellets for **blasting purposes**

part no. 4044250

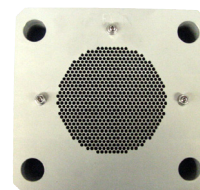

### i-Series

Enables remote access and data services via LAN, Ethernet, WiFi, 3G (other data services on demand)  
Discounts, features, period of validity and monthly subscription fees depend on the selected i-Series service contract.



## ASCO Dry Ice Pelletizer P28i-D3: Options

Pos. 001

### Extruder plate for 10 mm (3/8 ") pellets

Pellets for **cooling purposes**

part no. 4044255

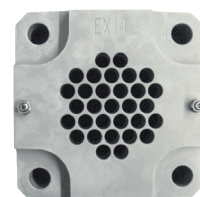

Pos. 002

### Extruder plate for 16 mm (5/8 ") pellets

Pellets for **cooling purposes**

part no. 4044253



Pos. 003

### Spare parts kit

Includes a recommended selection of spare parts to ensure constant operation.

part no. 4068376



Sample image

Pos. 004

### Connecting Kit 1" A220P/A240P/P15(i)/P28i

For flexible connection.

Length: 1.5 m

part no. 4044246



# Dry Ice Production

## ASCO Dry Ice Pelletizer P55i

part no. 901461

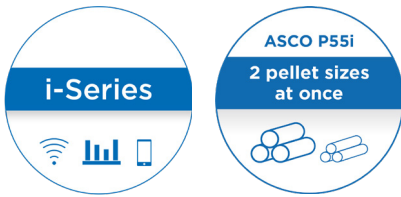

The **ASCO** Dry Ice Pelletizer P55i is one of the most powerful dry ice machines from **ASCO**'s i-Series line. Having a production capacity of 550 kg/h (1212 lb/h) it meets the demands for high dry ice quantities plus quality and flexibility in the daily working process.

As a model of **ASCO**'s i-Series, it is equipped with state-of-the-art remote control devices and thus is ready for a wide range of services in the areas of **Remote Access, Remote Data, Remote Management**.

Be it for fast and efficient trouble shooting and maintenance or for gathering production and performance data - the **ASCO** i-Series offers a wide range of possibilities to **link Industry 4.0 with dry ice production**.

The **ASCO** Dry Ice Pelletizer P55i is driven by two powerful hydraulic units, which are running **independently** by the push of a button. This allows the **production of identical or different pellet sizes** in combination with the offered extruder plates. All functions are controlled by a Siemens PLC with a 12" touch screen. A fully automatic control of oil temperature and dry ice snowing process guarantees continuous dry ice production without any supervision right from pushing the start button.

To maximise the CO<sub>2</sub> to dry ice conversion ratio to 90 - 95% the dry ice pelletizer can be connected to an **ASCO** Revert Gas Recovery System.

**Standardly equipped without extruder plates.**

Please refer to the options below.

### Specifications

Production capacity:	550 kg/h (1212 lb/h) ± 5 % at 16 - 19 bar (232-275 psi) CO <sub>2</sub> inlet pressure
Voltage:	400 VAC ± 5 % / 50 Hz / 3 Ph + PE (other voltages and frequencies on request)
Max. power consumption:	11.3 kW (15.2 HP)
Dimensions (L x W x H):	1'600 × 1'500 × 1'650 mm (63 x 59 x 65 in)
Weight net:	1'660 kg (3'660 lb) (without hydraulic oil) 1'770 kg (3'902 lb) (with hydraulic oil)
Weight packed:	approx. 1'830 kg (4'034 lb) (without hydraulic oil)
CO <sub>2</sub> inlet connection:	1" BSP female
CO <sub>2</sub> source:	CO <sub>2</sub> storage tank, liquid phase (16-20 bar) (232-290 psi)
Connectivity and remote access:	LAN, Ethernet, WiFi, 3G (other data services on demand)

## ASCO Dry Ice Pelletizer P55i: Function and applications



The **ASCO** Dry Ice Pelletizer P55i requires a liquid CO<sub>2</sub> supply (pressure 16-20 bar) (232-290 psi) and power supply of 400 V / 50 Hz /3 Ph + PE (other voltages available on request). The machine features instant push button start and all functions are controlled by an inbuilt PLC and operated via the 12" touch screen. Dry ice snow is injected into the two snow chambers, pressed and then extruded by two powerful and independent hydraulic units. Hard, dense dry ice pellets are produced shortly after pushing the start button.

To ensure continuous, reliable operation of the pelletizer, oil temperature, oil level, cycle time, injection time, operation hours, due date of service, motor overload, amount dry ice produced since last start, CO<sub>2</sub> inlet pressure and hydraulic pressure are all monitored and displayed on the touch screen of the P55i's PLC. This data can also be evaluated and stored permanently via suitable i-Series service contracts.

Various production modes enable a "non-stop" production, the production to a defined pre-set quantity or a fully automatic operation with input and output signals via the digital COM Interface.

### Options

The **ASCO** Dry Ice Pelletizer P55i is standardly not equipped with an extruder plate for the production of pellets. Optional extruder plates for the production of 3 mm (1/8 "), 10 mm (3/8 ") and 16 mm (5/8 ") pellets (for cooling purposes) are also available.

<b>Pellet size</b>	 3mm (1/8 ")	 10mm (3/8 ")	 16mm (5/8 ")
<b>Operating range</b>	Dry ice blasting	Cooling purposes	Cooling purposes

## ASCO Dry Ice Pelletizer P55i: Key features

- **PLC SIEMENS-ET200SP** - controls the complete process, injection and hydraulic
- **Siemens TP1200 Comfort 12 " Touch-Screen** - with different access levels and information regarding the ongoing production
- **Digital 24V COM Interface and remote control devices** - offers a wide range of possibilities to link Industry 4.0 with dry ice production
- **Independent performance** - very constant production, independent of pressure and temperature in the range of 16 - 20 bar (232 -290 psi) for both dry ice exits
- **Integrated production control system** - definition and supervision of production quantity per cylinder
- **High process reliability** - optimised process monitoring provides optimal performance and increases process reliability
- **Easy maintenance / optimal service planning** - comprehensive error history, indication on touch screen when next service is due and service history available
- **Minimum floor space for high production performance**



## ASCO Dry Ice Pelletizer P55i: Standard scope of delivery

### i-Series

Enables remote access and data services via LAN, Ethernet, WiFi, 3G (other data services on demand)  
Discounts, features, period of validity and monthly subscription fees depend on the selected i-Series service contract.



## ASCO Dry Ice Pelletizer P55i: Options

Pos. 001

### Extruder plate for 3 mm (1/8 ") pellets

Pellets for **blasting purposes**

part no. 4044250

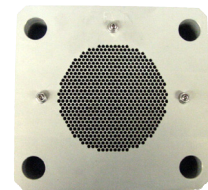

Pos. 002

### Extruder plate for 10 mm (3/8 ") pellets

Pellets for **cooling purposes**

part no. 4044255

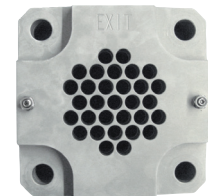

Pos. 003

### Extruder plate for 16 mm (5/8 ") pellets

Pellets for **cooling purposes**

part no. 4044253



Pos. 004

### Spare parts kit

Includes a recommended selection of spare parts to ensure constant operation.

part no. 4066011



Sample image

Pos. 005

### Connecting Kit 1" A220P/A240P/P15(i)/P28i/P55i

For flexible connection.

Length: 1.5 m

part no. 4044246



# Dry Ice Production

## ASCO Dry Ice Pelletizer P75i

part no. 901153



The Pelletizer P75i is the most powerful model in the range of **ASCO i-Series dry ice production machines**. At ASCO, i-Series stands for interconnected production. Be it for quick and efficient trouble shooting and maintenance or for gathering of production and performance data - the i-Series offers a wide range of options to link industry 4.0 dry ice production to industry 4.0.

The P75i is the workhorse among the ASCO dry ice pelletizers with a **production capacity of 750 kg/h (1'653 lb/h)**. It is built for long-term operation incorporating a heavy duty type hydraulic system controlled by an integrated PLC with touch screen interface. Fully automatic control of oil temperature and dry ice snow production process guarantees continuous dry ice production without any supervision right from the beginning.

By default, the P75i operates with a low noise level and can be optionally equipped with an automatic extruder plate changer. Simply change the production from one set pellet size to another size at the push of a button.

To maximise the CO<sub>2</sub> to dry ice conversion ratio the dry ice pelletizer can be connected to an **ASCO Revert Gas Recovery System**.

**Standardly equipped without extruder plate.**

Please refer to the options below.

### Specifications

Production capacity:	750 kg/h (1'653 lb/h)
Voltage:	400 VAC ± 5 %/50 Hz/3 Ph + PE (other voltages and frequencies on request)
Max power consumption:	19 kW (25.5 HP)
Dimension (L × W × H):	1'700 x 1'100 x 3'860 mm (67 x 44 x 152 in)
Weight net:	1'550 kg (3'410 lb) (without hydraulic oil & options) 1'800 kg (3'960 lb) (with hydraulic oil)
Weight packed:	2'250 kg (4'950 lb) (without hydraulic oil)
Ø consumption:	7.5 kW (10 HP)
Noise level P75i standard:	<79 dB(A)
CO <sub>2</sub> inlet connection:	1 × 1/2" BSP female CO <sub>2</sub> liquid 1 × 1/4" BSP female CO <sub>2</sub> gas
CO <sub>2</sub> source:	CO <sub>2</sub> storage tank, liquid phase (15-20 bar) (218-290 psi)
Connectivity and remote access:	LAN, Ethernet, WiFi, 3G (other data services on demand)

## ASCO Dry Ice Pelletizer P75i: Options

Pos. 001

### Extruder plate for 3 mm (1/8 ") pellets

Extruder plate for ASCO Dry Ice Pelletizer P75i  
**For manual plate exchange**

Pellets for **blasting purposes**

part no. 4045146

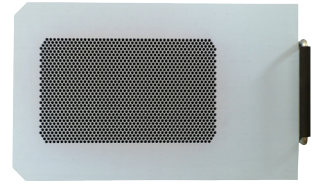

Pos. 002

### Extruder plate for 6 mm (1/4 ") pellets

Extruder plate for ASCO Dry Ice Pelletizer P75i  
**For manual plate exchange**

Pellets for **cooling purposes**

part no. 4045147

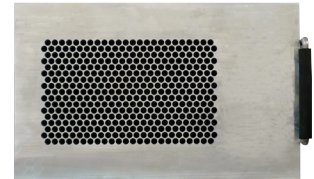

Pos. 003

### Extruder plate for 10 mm (3/8 ") pellets

Extruder plate for ASCO Dry Ice Pelletizer P75i  
**For manual plate exchange**

Pellets for **cooling purposes**

part no. 4045148

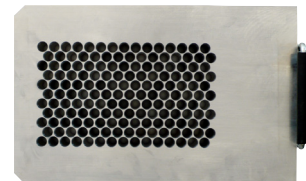

Pos. 004

### Extruder plate for 16 mm (5/8 ") pellets

Extruder plate for ASCO Dry Ice Pelletizer P75i  
**For manual plate exchange**

Pellets for **cooling purposes**

part no. 4045149

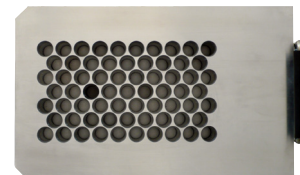

Pos. 005

### Extruder plate for 19 mm (3/4 ") pellets

Extruder plate for ASCO Dry Ice Pelletizer P75i  
**For manual plate exchange**

Pellets for **cooling purposes**

part no. 4045150

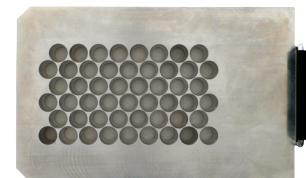

# ASCO Dry Ice Pelletizer P75i: Automatic Pellet Size Changer

Pos. 006

## Automatic pellet size changer for P75i

Option for automatic pellet size changeover between two determined diameters.

No extruder plates included. Please select the desired plates from the list of options.

part no. 4066382



Pos. 007

## Extruder plate for 3 mm (1/8 ") pellets

Extruder plate for ASCO Dry Ice Pelletizer P75i with automatic pellet size changer

Pellets for **blasting purposes**

part no. 4066385

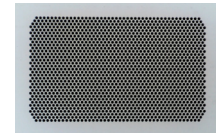

Pos. 008

## Extruder plate for 6 mm (1/4 ") pellets

Extruder plate for ASCO Dry Ice Pelletizer P75i with automatic pellet size changer

Pellets for **cooling purposes**

part no. 4066458

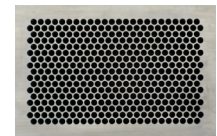

Pos. 009

## Extruder plate for 10 mm (3/8 ") pellets

Extruder plate for ASCO Dry Ice Pelletizer P75i with automatic pellet size changer

Pellets for **cooling purposes**

part no. 4066459

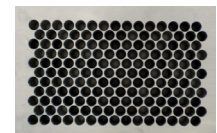

Pos. 010

## Extruder plate for 16 mm (5/8 ") pellets

Extruder plate for ASCO Dry Ice Pelletizer P75i with automatic pellet size changer

Pellets for **cooling purposes**

part no. 4066386

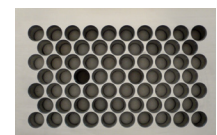

Pos. 011

## Extruder plate for 19 mm (3/4 ") pellets

Extruder plate for ASCO Dry Ice Pelletizer P75i with automatic pellet size changer

Pellets for **cooling purposes**

part no. 4066460

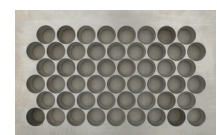

## ASCO Dry Ice Pelletizer P75i: Options

Pos. 012

### ASCO Spare parts kit for P75i CE

Includes a recommended selection of spare parts to ensure constant operation.

part no. 4066501



Sample image

Pos. 013

### Exhaust pipe set 250 - 160

For discharging exhaust gas into the atmosphere.  
Height approx. 300 cm / 100"

part no. 4045163



Sample image

# Dry Ice Production

## ASCO Automatic Dry Ice Machine BP420i

part no. 900127



ASCO's automatic Dry Ice Machine BP420i produces slices in 10 different thicknesses and 2 different types of pellets at the push of a button.

The dies for the production of different sizes do not have to be changed manually as they are already built in and can be controlled at the touch screen panel. The BP420i features high density, fully automatic dry ice production for slices in ten different thicknesses. In addition, it is possible to produce pellets in two different sizes with a diameter of 3, 6, 10 or 16 mm (1/8, 1/4, 3/8 or 5/8 "). Standard slice dimensions are 210 × 125 × 20-70 mm (8.3 x 4.9 x 0.8-2.8in). Other slice/pellet dimensions are available on request. Depending on the setting, the production capacity ranges from 240 to 400kg/h (529 to 882lb/h).

By default, the BP420i operates with a low noise level.

The automatic dry ice block, slice and pellet machine **ASCO** BP420i belongs to the **ASCO** i-Series line. It's equipped with state-of-the-art remote control devices and thus is ready for a wide range of services in the areas of **Remote Access, Remote Data, Remote Management**.

Be it for fast and efficient trouble shooting and maintenance or for gathering production and performance data - the **ASCO** i-Series offers a wide range of possibilities to **link Industry 4.0 with dry ice production**.

To maximise the CO<sub>2</sub> to dry ice conversion ratio the dry ice machine can be connected to an **ASCO** Revert Gas Recovery System.

### Specifications

Production capacity:	400 kg/h (880 lb/h)
Voltage:	400 VAC ± 5 % / 50 Hz / 3 Ph + PE (other voltages and frequencies on request)
Dimension (L × W × H):	2'540 x 1'100 x 3'750 mm (100 x 44 x 148 in)
Weight net:	1'700 kg (3'740 lb) (without hydraulic oil & options) 1'900 kg (4'180 lb) (with hydraulic oil)
Weight packed:	2'300 kg (5'060 lb) (without hydraulic oil)
Average power consumption:	6 kW (8 HP)
Noise level BP420i standard:	< 82 dB (A)
CO <sub>2</sub> inlet connection:	1 × 1/2" BSP female CO <sub>2</sub> liquid 1 × 1/4" BSP female CO <sub>2</sub> gas
CO <sub>2</sub> source:	CO <sub>2</sub> storage tank, liquid phase (15-20 bar) (218-290 psi)
Connectivity and remote access:	LAN, Ethernet, 3G (other data services on demand)

## ASCO Automatic Dry Ice Machine BP420i: Key features

- **SIEMENS PLC SIMATIC ET-200S** - controls the whole process, injection and hydraulic for continuous automatic operation
- **New ASCO HMI** - multilingual 7" touch screen with different access levels, adjustable parameters, on-line production and product information as well as history file for supervisor
- **Remote control devices** - offers a wide range of possibilities to link Industry 4.0 with dry ice production
- **Profibus network** for fast communication between PLC and the numerically controlled hydraulic piston pump for a precise control of the flow and pressure to optimize the dry ice quality
- **Linear encoder** - for precise position control of piston and shutter plate (PCO)
- **Independent oil cooling and filtration system (ICFS)** - to increase lifetime of hydraulic equipment and to reduce oil consumption
- **10 different slice thicknesses and 2 pellet sizes** - possible at the push of a button (to be specified at time of order)
- **Auto-compensation** - of CO<sub>2</sub> pressure and temperature variation of CO<sub>2</sub> storage tank (ACPT) to ensure slice thickness control fully automatic
- **High quality stainless steel pressing chamber** - to protect the chamber against corrosion and reduce the cost of maintenance
- **Slide incl. slice speed reducing device** to appropriately decelerate the produced blocks for further processing
- **CO<sub>2</sub> gas recovery possible**
- **Easy operation and maintenance**
- **Simple and quick installation**
- **European standard CE**
- **Quality components, e.g. Siemens, ATOS**

### Slice, block and pellet information

Dry ice product	Standard block / slice dimensions 210 × 125 mm (8.3 x 4.9 in)										Pellets
Thickness in mm (Thickness in in)	20 (0.8)	22 (0.9)	25 (1)	30 (1.2)	35 (1.4)	40 (1.6)	45 (1.8)	50 (1.9)	60 (2.4)	70 (2.8)	all Ø
Weight in gr/slice (Weight in lb/slice)	820 (1.8)	900 (2.0)	1'020 (2.2)	1'210 (2.7)	1'410 (3.1)	1'620 (3.6)	1'820 (4.0)	2'020 (4.5)	2'420 (5.3)	2'830 (6.2)	-
Capacity in kg/h (Capacity in lb/h)	240 (529)	250 (551)	300 (661)	240 (529)	270 (595)	300 (661)	330 (728)	350 (772)	330 (728)	390 (860)	400 (882)

This choice of sizes is only an extract and helps as production indication. The thickness of the blocks is adjustable by 1 mm from 20 to 70 mm (0.8 to 2.8 in). Our machines can be made to produce almost any size of slices / blocks upon special request. If you have a special need, please let us know.

Standard pellets sizes are diameters of 3, 6, 10 or 16 mm (1/8, 1/4, 3/8 or 5/8"). Other sizes are available on request.

## Automatic ASCO Dry Ice Machine BP420i: Applications

Airline catering (20-25 mm thickness) (0.8 -1 in), transport cooling (thicker blocks) or pellets for other cooling or for dry ice blasting purposes: The automatic **ASCO** Dry Ice Machine BP420i produces high quality dry ice blocks, slices and pellets to cover all different market requests.

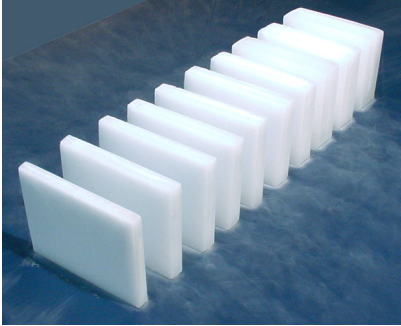

### Catering services

10 different slice thicknesses

- Airline trolleys
- Transport cooling
- etc.



### Cooling

6, 10 and 16 mm pellets (1/4, 3/8, 5/8")

- Food transportation
- Fishing industry
- Ice cream industry
- Laboratories
- Wineries
- etc.



### Dry ice blasting

3 mm pellets (1/8 ")

- Foundries
- Tyre production
- Rubber-, food- and printing industry
- etc.

## Automatic ASCO Dry Ice Machine BP420i: Options

Pos. 001

### Ice Loader for Dry Ice blocks/ slices

For reasons of weight and occupational health and safety, we recommend using the Ice Loader instead of the standard block brake for a controlled and timed handover of blocks / slices from 1.2 kg (2.7 lb) or 30 mm (1.2 in) thickness.

The Ice Loader is tailored to the production capacities of the BP420i and designed for the standard block / slice sizes of 210 × 125 mm (8.3 × 4.9 in). It has its own electrical switch cabinet with logo PLC control and is controlled and protected via the main switch cabinet of the BP420i.

A pneumatic connection is required for mechanical operation (min. 6 bar).

For the production of dry ice pellets, the Ice Loader can be manually decoupled from the dry ice machine.

part no. 901151





## Automatic ASCO Dry Ice Machine BP420i: Options

Pos. 002

### Upgrade D3mm (1/8 ")

To produce 3 mm (1/8 ") pellets in addition to blocks with the same machine at the press of a button.

Capacity with 3 mm (1/8 ") pellets = 400 kg/h (882lb/h)

part no. 22858

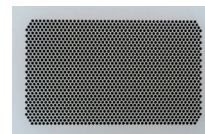

Pos. 003

### Upgrade D6mm (1/4 ")

To produce 6 mm (1/4 ") pellets in addition to blocks with the same machine at the press of a button.

Capacity with 6 mm (1/4 ") pellets = 400 kg/h (882lb/h)

part no. 22861

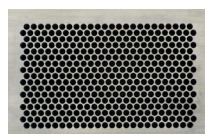

Pos. 004

### Upgrade D10mm (3/8 ")

To produce 10 mm (3/8 ") pellets in addition to blocks with the same machine at the press of a button.

Capacity with 10 mm (3/8 ") pellets = 400 kg/h (882 lb/h)

part no. 22859

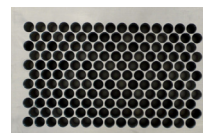

Pos. 005

### Upgrade D16mm (5/8 ")

To produce 16 mm (5/8 ") pellets in addition to blocks with the same machine at the press of a button.

Capacity with 16 mm (5/8 ") pellets = 400 kg/h (882lb/h)

part no. 22860

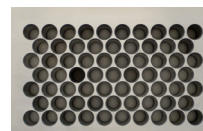

Pos. 007

### Set of spares

Recommended set of spare parts for approx. one to two years normal operation.

part no. 4045162



Sample image

Pos. 007

### Exhaust pipe set 250 - 160

For discharging exhaust gas into the atmosphere.  
Height approx. 300 cm / 100"

part no. 4045163



Sample image

# Dry Ice Production

## ASCO Automatic Dry Ice Machine BP425i

part no. 901350



ASCO's automatic Dry Ice Machine BP425i produces slices in ten different thicknesses and two different types of pellets at the push of a button.

The dies for the production of different sizes do not have to be changed manually as they are already built-in and can be controlled at the touch screen panel. The BP425i features high density, fully automatic dry ice production for slices in ten different thicknesses. In addition, it is possible to produce pellets in two different sizes with a diameter of 3, 6, 10 or 16 mm (1/8, 1/4, 3/8 or 5/8"). Standard slice dimensions are 210 × 125 × 20 - 125 mm (8.3 × 4.9 × 0.8 - 4.9 in). Other slice/pellet dimensions are available on request. Depending on the setting, the production capacity ranges from 190 to 400 kg/h (418 to 882 lb/h).

By default, the BP425i operates with a low noise level.

The automatic dry ice block, slice and pellet machine **ASCO** BP425i belongs to the **ASCO** i-Series line. It is equipped with state-of-the-art remote control devices and thus is ready for a wide range of services in the areas of **Remote Access, Remote Data, Remote Management**.

Be it for fast and efficient trouble shooting and maintenance or for gathering production and performance data - the **ASCO** i-Series offers a wide range of possibilities to **link Industry 4.0 with dry ice production**.

To maximise the CO<sub>2</sub> to dry ice conversion ratio the dry ice machine can be connected to an **ASCO** Revert Gas Recovery System.

### Specifications

Production capacity:	400 kg/h (882 lb/h) (Pellets)
Voltage:	400 VAC ± 5 %/50 Hz/3 Ph + PE (other voltages and frequencies on request)
Dimension (L × W × H):	2'540 × 1'100 × 3'750 mm (100 × 44 × 148 in)
Weight net:	1'700 kg (3'740 lb) (without hydraulic oil & options) 1'900 kg (4'180 lb) (with hydraulic oil)
Weight packed:	2'300 kg (5'060 lb) (without hydraulic oil)
Average power consumption:	6 kW (8 HP)
Noise level BP425i standard:	< 82 dB (A)
Verified breakage rate (slices/ blocks):	< 3%
CO <sub>2</sub> inlet connection:	1 × 1/2" BSP female CO <sub>2</sub> liquid 1 × 1/4" BSP female CO <sub>2</sub> gas
CO <sub>2</sub> source:	CO <sub>2</sub> storage tank, liquid phase (15-20 bar) (218-290 psi)
CO <sub>2</sub> conversion rate:	approx. 43% (without optional Revert Recovery System)
Connectivity and remote access:	LAN, Ethernet, 3G (other data services on demand)

## ASCO Automatic Dry Ice Machine BP425i: Key features

- **SIEMENS PLC SIMATIC ET-200S** - controls the whole process, injection and hydraulic for continuous automatic operation
- **New ASCO HMI** - multilingual 7" touch screen with different access levels, adjustable parameters, on-line production and product information as well as history file for supervisor
- **Remote control devices** - offers a wide range of possibilities to link Industry 4.0 with dry ice production
- **Profibus network** for fast communication between PLC and the numerically controlled hydraulic piston pump for a precise control of the flow and pressure to optimize the dry ice quality
- **Linear encoder** - for precise position control of piston and shutter plate (PCO)
- **Independent oil cooling and filtration system (ICFS)** - to increase lifetime of hydraulic equipment and to reduce oil consumption
- **10 different slice thicknesses and 2 pellet sizes** - possible at the push of a button (to be specified at time of order)
- **Auto-compensation** - of CO<sub>2</sub> pressure and temperature variation of CO<sub>2</sub> storage tank (ACPT) to ensure slice thickness control fully automatic
- **High quality stainless steel pressing chamber** - to protect the chamber against corrosion and reduce the cost of maintenance
- **Slide incl. slice speed reducing device** to appropriately decelerate the produced blocks for further processing
- **CO<sub>2</sub> gas recovery possible**
- **Easy operation and maintenance**
- **Simple and quick installation**
- **European standard CE**
- **Quality components, e.g. Siemens, ATOS**

### Slice, block and pellet information

Dry ice product	Standard block / slice dimensions 210 × 125 mm (8.3 x 4.9 in)										Pellets
Thickness in mm (Thickness in in)	20 (0.8)	22 (0.9)	25 (1.0)	30 (1.2)	40 (1.6)	50 (1.9)	60 (2.4)	70 (2.8)	100 (3.9)	125 (4.9)	all Ø
Weight in gr/slice (Weight in lb/slice)	820 (1.8)	900 (2.0)	1'020 (2.2)	1'210 (2.7)	1'620 (3.6)	2'020 (4.4)	2'420 (5.3)	2'830 (6.2)	4'000 (8.8)	5'000 (11.0)	-
Capacity in kg/h (Capacity in lb/h)	200 (441)	220 (485)	250 (551)	190 (418)	250 (551)	300 (661)	280 (617)	330 (727)	350 (771)	380 (837)	400 (882)

This choice of sizes is only an extract and helps as production indication. The thickness of the blocks is adjustable by 1 mm from 20 to 125 mm (0.8 to 4.9 in). Our machines can be made to produce almost any size of slices / blocks upon special request. If you have a special need, please let us know.

Standard pellets sizes are diameters of 3, 6, 10 or 16 mm (1/8, 1/4, 3/8 or 5/8").

## Automatic ASCO Dry Ice Machine BP425i: Applications

Airline catering (20-25 mm thickness) (0.8 - 1.0 in), transport cooling (thicker blocks) or pellets for other cooling or for dry ice blasting purposes: The automatic **ASCO** Dry Ice Machine BP425i produces high quality dry ice blocks, slices and pellets to cover all different market requests.

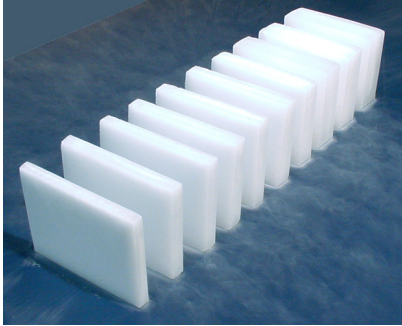

### Catering services

10 different slice thicknesses

- Airline trolleys
- Transport cooling
- etc.



### Cooling

6, 10 and 16 mm pellets (1/4, 3/8, 5/8")

- Food transportation
- Fishing industry
- Ice cream industry
- Laboratories
- Wineries
- etc.



### Dry ice blasting

3 mm pellets (1/8")

- Foundries
- Tyre production
- Rubber-, food- and printing industry
- etc.

## Automatic ASCO Dry Ice Machine BP425i: Options

Pos. 001

### Ice Loader for Dry Ice blocks/ slices

For reasons of weight and occupational health and safety, we recommend using the Ice Loader instead of the standard block brake for a controlled and timed handover of blocks / slices from 1.2 kg (2.7 lb) or 30 mm (1.2 in) thickness.

The Ice Loader is tailored to the production capacities of the BP425i and designed for the standard block / slice sizes of 210 x 125 mm (8.3 x 4.9 in). It has its own electrical switch cabinet with logo PLC control and is controlled and protected via the main switch cabinet of the BP425i.

A pneumatic connection is required for mechanical operation (min. 6 bar).

For the production of dry ice pellets, the Ice Loader can be manually decoupled from the dry ice machine.

part no. 901151



## Automatic ASCO Dry Ice Machine BP425i: Options

Pos. 002

### Upgrade D3 mm (1/8 ")

To produce 3 mm (1/8 ") pellets in addition to blocks with the same machine at the press of a button.

Capacity with 3 mm (1/8 ") pellets = 400 kg/h (882lb/h)

part no. 22858

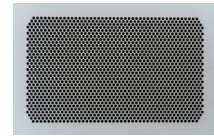

Pos. 003

### Upgrade D6 mm (1/4 ")

To produce 6 mm (1/4 ") pellets in addition to blocks with the same machine at the press of a button.

Capacity with 6 mm (1/4 ") pellets = 400 kg/h (882lb/h)

part no. 22861

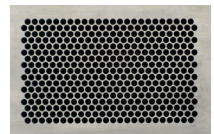

Pos. 004

### Upgrade D10 mm (3/8 ")

To produce 10 mm (3/8 ") pellets in addition to blocks with the same machine at the press of a button.

Capacity with 10 mm (3/8 ") pellets = 400 kg/h (882 lb/h)

part no. 22859

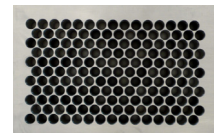

Pos. 005

### Upgrade D16 mm (5/8 ")

To produce 16 mm (5/8 ") pellets in addition to blocks with the same machine at the press of a button.

Capacity with 16 mm (5/8 ") pellets = 400 kg/h (882lb/h)

part no. 22860

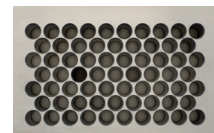

Pos. 006

### Set of spares

Recommended set of spare parts for approx. one to two years normal operation.

part no. 4045162



Sample image

Pos. 007

### Exhaust pipe set 250 - 160

For discharging exhaust gas into the atmosphere.  
Height approx. 300 cm / 100"

part no. 4045163



Sample image

# Dry Ice Production

## ASCO Dry Ice Reformer R70i

part no. 901510



The **ASCO** Dry Ice Reformer R70i has been developed for producing dense dry ice blocks in various sizes by compressing dry ice pellets. **Be it in combination with an existing or with a new dry ice pelletizer, the ASCO Dry Ice Reformer R70i is a very convenient tool to complement the dry ice pellet business with dry ice blocks.**

The compact machine is driven by a powerful and unique hydraulic unit featuring instant push button start. All functions are controlled by a Siemens PLC. A Siemens touch screen provides good overview and easy operation, a comprehensive monitoring, easy maintenance and optimal service planning. An integrated production control system allows to define and supervise the amount of blocks or weight to be produced.

### Specifications

Production capacity*:	300 to 700 kg/h (661 - 1543 lb) (depending on block size)
Voltage:	400 VAC ± 5 %/50 Hz/3 Ph + PE (other voltages and frequencies on request)
Dimensions (L × W × H):	1'140 × 1'140 × 1'620 mm (45 x 45 x 64 in)
Weight net:	approx. 510 kg (1122 lb) (without hydraulic oil) approx. 580 kg (1276 lb) (with hydraulic oil)
Weight packed:	680 kg (1499 lb)
Total power installed:	9.5 kW (12.7 HP)
Max. average power consumption:	< 3 kW (4 HP)
Standby mode:	0.6 kW (0.8 HP)
Connectivity and remote access:	LAN, Ethernet, 3G (other data services on demand)
Basis media:	3 mm (1/8 ") dry ice pellets
Dry ice density blocks:	≥ 1.54 kg/dm <sup>3</sup> (96 lb/ft <sup>3</sup> )
Standard block/slice sizes:	210 × 125 mm (8.3 x 4.9 in), thickness 16 to 60 mm (0.6 to 2.3 in) resp. weight 650 to 2'430 g (1.4 to 5.4 lb) (thickness and weight stepless adjustable)

	Standard block /slice size 210 × 125 mm (8.3 x 4.9 in)								
Thickness in mm** (Thickness in in)	16 (0.6)	18 (0.7)	20 (0.8)	22 (0.9)	25 (1)	30 (1.2)	40 (1.6)	50 (2)	60 (2.4)
Weight in g/block approx. (Weight in lb/block approx.)	650 (1.4)	730 (1.6)	810 (1.8)	890 (2)	1'010 (2.2)	1'220 (2.7)	1'620 (3.6)	2'030 (4.5)	2'430 (5.4)
Performance in kg/h approx. (Performance in lb/h approx.)	300 (661)	320 (705)	336 (741)	370 (816)	400 (882)	460 (1014)	562 (1'239)	649 (1'431)	700 (1'543)

\* The indications regarding production capacity are based on the use of 3 mm pellets, freshly produced on ASCO dry ice pelletizers.

\*\* This choice of sizes is only an extract and helps as production indication. The thickness or the weight of the blocks is alternatively stepless adjustable.

## ASCO Dry Ice Reformer R70i: Function and applications

The **ASCO** Dry Ice Reformer R70i is started on the 7" Siemens comfort touch screen panel. All functions are controlled by the inbuilt PLC. Dry ice pellets with a diameter of 3 mm (1/8 ") are filled into the dry ice hopper. From there they are conveyed to the pressing chamber automatically, where they are predosed and compressed into high-quality dry ice blocks.

To ensure continuous, reliable operation of the reformer, oil level, cycle time, operation hours, due date of service, motor overload, amount of produced dry ice blocks since last start and hydraulic pressure are all monitored and displayed on the touch screen of the R70i's PLC.

### Dry Ice Reformer R70i: Key features

- **SIEMENS PLC** - controls the complete process, filling of the pressing chamber and the hydraulic with its main and side cylinder.
- **Siemens comfort touch screen 7" HMI** - Multilingual 7" Touch-Screen with different access levels and adjustable parameters.
- **Integrated production control system** - definition and supervision of amount of blocks or weight to be produced.
- **Alternatively thickness or weight of blocks stepless adjustable** (16 to 60 mm (0.6 to 2.4 in) resp. 650 to 2'430 g (1.4 to 5.4 lb). Corresponding calculation happens automatically.
- **Integrated block thickness control and fill level monitoring** - if the required amount of dry ice pellets in the hopper falls short, the machine automatically goes into a waiting mode until the correct fill level is reached again.
- **High process reliability** - optimal process monitoring provides optimal performance and high process reliability.
- **Remote control devices** - offers a wide range of possibilities to link Industry 4.0 with dry ice production
- **System integration** - can be combined with all ASCO pelletizer and ASCO packaging machines APM120.

## Automatic Dry Ice Reformer R70i: Options

Pos. 001

### Podium for Dry Ice Pelletizer

Customized podium to elevate a dry ice pelletizer to directly charge the ASCO Dry Ice-Reformer R70i with pellets.

part no. 4063845



Pos. 002

### ASCO Pellet Feeder for Dry Ice Reformer R70i

Conveyor belt for automatic filling of the R70i dry ice reformer with pellets from an ASCO P15i or P28i dry ice pelletizer.

part no. 4063846



Pos. 003

### ASCO Pellet Feeder for Dry Ice Reformer R70i

Universal conveyor belt for automatic filling of the R70i dry ice reformer with pellets from all ASCO dry ice pelletizers.

part no. 4070842



Pos. 004

### Set of spares

Recommended set of spare parts for approx. one to two years normal operation.

part no. 4063494



Sample image



# Dry Ice Production / Sawing

## ASCO Dry Ice Active Saw - AAS

part. no. 901470



The electric dry ice active saw **ASCO AAS** was specially designed for cutting dry ice slices. Thanks to an output of up to 600 slices per hour, it is suitable for being operated in conjunction with several dry ice production machines. The dry ice blocks can either be cut in half with a saw blade or cut into three equally sized slices with two saw blades.

Different production centers are possible in combination with the ASCO dry ice machines BP420i, BP425i, the reformer R70i as well as with the ASCO packaging machines AMP120 and APM140. The standard layouts are listed for each of the packaging machines.

The machine is supplied with one saw blade as standard, if necessary it can be converted to the optional double saw blades within a few minutes. The operating speed of the dry ice saw is fixed via the motor speed.

### Specifications

Dimensions (L × W × H):	1'902 × 816 × 1'363 mm (75 x 32x 54 in)
Sawing performance:	600 dry ice blocks per hour
Block dimensions (L × W):	125 mm x 210 mm or 254 mm (5 in x 8 in or 10 in)
Block thickness (H):	16-70 mm (0.6 - 2.8 in)
Sound level:	max. 81 dB (A)
Drive:	electric motor
Electrical power supply:	400 VAC / 7.5A / 50Hz / 3 phases + earth (other voltages and frequencies on request with extra charge)
Motor power:	3.0kW (4 hp)
Net weight:	280 kg (617 lb)
Packed weight:	approx. 350 kg (approx. 772 lb)

## ASCO Dry Ice Active Saw - AAS

Pos. 001

### ASCO AAS01

Active dry ice saw for sawing (halving) blocks of dry ice.

The machine is supplied with one saw blade and is ready for use immediately.

part no. 901470



## ASCO Dry Ice Active Saw - AAS: Options

Pos. 001

### Saw blade shaft with 2 saw blades

For cutting the dry ice blocks into 3 equal slices.

part no. 4068584

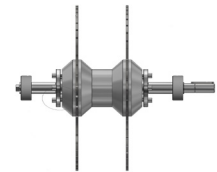

Pos. 002

### Spare parts kit

Includes a recommended selection of spare parts to ensure constant operation.

part no. 4068852



Example picture

# Dry Ice Production / Wrapping

## ASCO Automatic Wrapping Machine APM120



The automatic wrapping machine ASCO APM120 has been specifically developed for wrapping dry ice slices. Thanks to its output of up to 60 slices per minute the APM120 can be used in combination with multiple dry ice production machines.

The operating speed can be individually adapted at the central control panel.

All our standard versions offered are listed hereafter.

The dimension of the dry ice slices to be wrapped has to be specified at the time of ordering. The machine is being delivered with one roll of wrapping film which is needed for initial set up and for commissioning at site.

### Specifications

Dimensions (L x W x H):	3'670 × 956 × 1'720 mm (144 x 38 x 68 in)
Performance:	Up to 60 slices/min (depending of dry ice production machine)
Wrapping material:	Polypropylen MD447/40 (Standard),
Product size (L x W x H):	Up to 210 mm × 125 mm (8 x 5 in) at 18 - 25 mm (0.7 - 1.0 in) thickness (has to be specified at time of order) Minimum length 70 mm (2.8 in)
Running direction:	Right-sided as standard (looking at the machine from the front, the product is fed in from the right and the packed slices are discharged on the left)
Air supply:	6 bar (87 psi)
Air consumption:	120 liters/min. of filtered and dry compressed air
Voltage:	400 VAC ± 5 %/50 Hz/3 Ph + PE + N (other voltages and frequencies on request)
Total power installed:	6.5 - 11.5 kW (8.7 - 15.4 HP)
Auxiliary circuits:	24 VDC
Net weight:	Approx. 550 kg (1'212 lb)
Film reel:	Max. width 500 mm (17 in) (standard 340 mm (13 in) depending of slice dimensions) Max. reel diameter 350 mm (14 in) Core diameter 70-76 mm (2.8 - 3 in)

## Automatic Wrapping Machine APM120: Versions for BP420

Pos. 001

### Automatic Wrapping Machine APM120 non extendable

Automatic wrapping machine designed to run with 1 x BP420  
without option for extension.

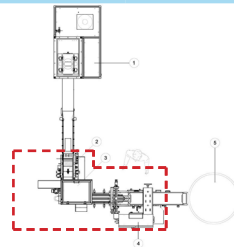

part no. 4064787

Pos. 002

### Automatic Wrapping Machine APM120 for 1 BP420, extendable

Automatic wrapping machine designed to run with 1 x BP420,  
extendable to run with 2 x or 3 x BP420

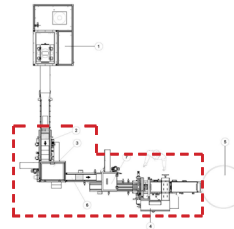

part no. 4064786

Pos. 003

### Automatic Wrapping Machine APM120 for 2 BP420, extendable

Automatic wrapping machine designed to run with 2 x BP420,  
extendable to run with 3 x BP420

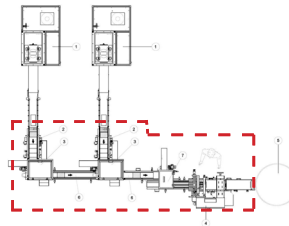

part no. 4064788

Pos. 004

### Automatic Wrapping Machine APM120 for 3 BP420

Automatic wrapping machine designed to run with 3 x BP420

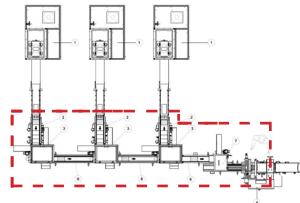

part no. 4064789

## Automatic Wrapping Machine APM120: Versions for Reformer R70i

Pos. 001

### Automatic Wrapping Machine APM120 for ASCO Dry Ice Reformer R70i

Automatic wrapping machine designed to run with the  
ASCO Dry Ice Reformer R70i

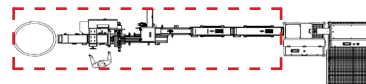

part no. 901214

## Automatic Wrapping Machine APM120: Options

### Pos. 001

#### Rotary table for ASCO Wrapping Machine Ø 1.2 m

Low quantity buffering device complete with:

- metallic support with three legs
- rotating table
- motor

part no. 4045179



### Pos. 002

#### Packaging film unprinted

With 340 mm (13.4 in)

Length approx. 1'400 running meters

Thickness 40 µm

Corporate branding upon request.

part no. 4045171



# Dry Ice Production / Bagging

## ASCO Pellets Bagging Machine PBM



With its packaging machine PBM, **ASCO** is presenting a compact solution for automated bagging of dry ice pellets. Three models are available depending on the intended filling quantity:

- **PBM 500** for bags from 0.5 kg to 3.0 kg (1.1 to 6.6 lb)
- **PBM 1000** for bags from 0.5 kg to 7.0 kg (1.1 to 15.4 lb)
- **PBM 1500** for bags from 3.0 kg to 11.0 kg (6.6 to 24.2 lb)

The **ASCO** PBM is equipped with an accurate weighing system and is optimised for packing dry ice pellets with a diameter of 3 to 16 mm (0.12 to 0.63 in).

The packaging machine comes with an auger elevator to connect with the dry ice pelletizer and a discharge conveyor. The bag size setting is changed via touch panel with the pre-set possibility for 250 programs.

Specifications	PBM 500	PBM 1000	PBM 1500
Performance (kg/h):	up to 700 kg/h (1'540 lb/h) bags of 0.5 kg (1.1 lb) approx. 400kg/h (882 lb/h)	up to 1000 kg/h (2'200 lb/h) bags of 0.5 kg (1.1 lb) approx. 400kg/h (882 lb/h)	up to 1500 kg/h (3'300 lb/h)
Tolerance max.:	0.5 - 3.0 kg bag: ±50 g (1.1 - 6.6 lb bag: ± 0.1 lb)	0.5 - 3.0 kg bag: ±50 g (1.1 - 6.6 lb bag: ± 0.1 lb) 3.0 - 6.0 kg bag: ±100 g (6.6 - 13.2 lb bag: ± 0.2 lb) 6.0 - 7.0 kg bag: ±150 g (13.2 - 15.4 lb bag: ± 0.3 lb)	3.0 - 6.0 kg bag: ±100 g (6.6 - 13.2 lb bag: ± 0.2 lb) 6.0 - 11.0 kg bag: ±200g (13.2 - 24.2 lb bag: ± 0.4 lb)
Max. foil width:	530 mm (21.0 in)	680 mm (26.8 in)	950 mm (37.4 in)
Bag size (W x L):	32 x 60 mm to 250 x 400 mm (1.3 x 2.4 in to 9.8 x 15.7 in)	32 x 60 mm to 320 x 400 mm (1.3 x 2.4 in to 12.6 x 15.7 in)	50 x 60 to bis 455 x 600 mm (2 x 2.4 in to 17.9 x 23.6 in)
Voltage:	400 VAC ± 5 % / 50 Hz / 3 Ph + PE + N (other voltages and frequencies on request)		
Power consumption:	5 kW (6.7 HP)	7 kW (9.4 HP)	8 kW (10.7 HP)
Pneumatic supply:	6 bar (87 psi); max 100 l/min (depends on bag size)		
Weight machine:	approx. 400 kg (882 lb)	approx. 530 kg (1168 lb)	approx. 850 kg (1874 lb)
Weight conveyors:	200 / 70 kg (441 / 154 lb)	200 / 70 kg (441 / 154 lb)	200 / 70 kg (441 / 154 lb)
Dimensions (L x W x H)	6.9 x 1.4 x 3.0 m (22.6 x 4.6 x 9.9 ft)	7.3 x 1.3 x 3.0 m (24 x 4.3 x 9.9 ft)	8.2 x 1.7 x 3.5 m (27 x 5.6 x 11.5 ft)

## ASCO Pellets Bagging Machine - PBM

Pos. 001

### ASCO PBM 500

Automatic bagging machine for dry ice pellets in bags of 0.5 to 3.0 kg (1.1 to 6.6 lb)

Including auger elevator to connect to the dry ice pelletizer and discharge conveyor

Delivered with a set of spare parts and one roll of packaging film which is needed for installation

part no. 901220

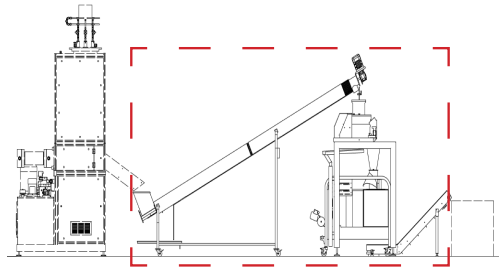

Pos. 002

### ASCO PBM 1000

Automatic bagging machine for dry ice pellets in bags of 0.5 to 7.0 kg (1.1 to 15.4 lb)

Including auger elevator to connect to the dry ice pelletizer and discharge conveyor

Delivered with a set of spare parts and one roll of packaging film which is needed for installation

part no. 901221

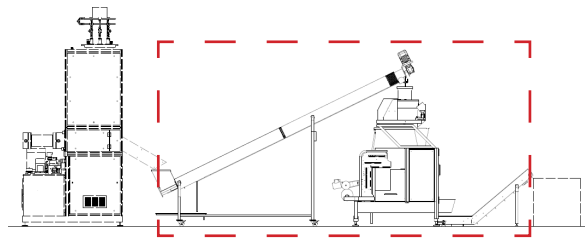

Pos. 003

### ASCO PBM 1500

Automatic bagging machine for dry ice pellets in bags of 3.0 to 11.0 kg (6.6 to 24.2 lb)

Including auger elevator to connect to the dry ice pelletizer and discharge conveyor

Delivered with a set of spare parts and one roll of packaging film which is needed for installation

part no. 901222

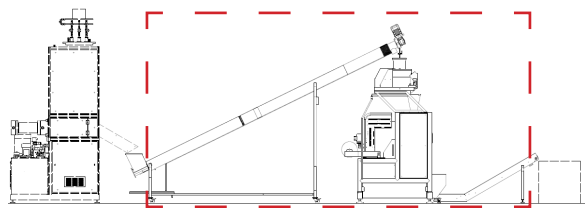

## Automatic Pellets Bagging Machine PBM: Options

Pos. 001

### Rotary table Ø 1.2 m (11 in)

Low quantity buffering device complete with:

- Metallic support with three legs
- Rotating table
- Motor

part no. 4045179



Pos. 002

### Packaging film neutral for PBM 500 perforated

Width: 530 mm (21 in)

Strength: 80 µm

Length / roll: 500 m (1'640 ft)

Weight: 20 kg (44 lb)

Core diameter: 77 mm (3 in)

part no. 4066962



## Automatic Pellets Bagging Machine PBM: Options

Pos. 003

### Packaging film neutral for PBM 1000 perforated

Width: 680 mm (27 in)  
Strength: 100 µm  
Length / roll: 500 m (1'640 ft)  
Weight: 32 kg (71 lb)  
Core diameter: 77 mm (3 in)

part no. 4066963



Pos. 004

### Packaging film neutral for PBM 1500 perforated

Width: 950 mm (37 in)  
Strength: 120 µm  
Length / roll: 400 m (1'312 ft)  
Weight: 43 kg (95 lb)  
Core diameter: 77 mm (3 in)

part no. 4066964



Pos. 005

### ASCO Dry Ice Container AT240W

Foam insulated polyethylene container for dry ice storage with wheels  
Cubic capacity: approx. 240 litres (8.5 ft<sup>3</sup>)  
Capacity with pellets: approx. 188 kg (414 lb)  
Average storage loss: 4.0 % per day  
Dimensions (L x W x H): 1'150 x 705 x 1'020 mm  
(45x 28 x 40 in)

part no. 4063652



Pos. 006

### ASCO Dry Ice Container AT440

Foam insulated polyethylene container for dry ice storage.  
Cubic capacity: approx. 440 litres (15.5 ft<sup>3</sup>)  
Capacity with pellets: approx. 344 kg (758 lb)  
Average storage loss: 4.1 % per day  
Dimensions (L x W x H): 1'175 x 800 x 990 mm  
(46 x 32 x 39 in)

part no. 4064262





# Dry Ice Production / Dosing

## ASCO Dry Ice Refilling System ARS

part no. 901501



The automatic ASCO Dry Ice Refilling System ARS was specially developed to **transfill dry ice pellets of various sizes precisely and as required into different containers and shipping boxes**. A special device lifts up already loaded storage containers and tilts the pellets into an insulated storage hopper, from where the required quantities of pellets can be precisely and steplessly dosed into smaller storage boxes using an oscillating conveyor feeder and a digital weighing system. The ASCO Dry Ice Refilling System ARS is an excellent and highly efficient tool to complement the dry ice pellet logistic. **It was developed especially for the pharmaceutical, food and logistics industries and can be used without local dry ice production.**

**The compact machine consists of a combination of lift-and-tilt unit, a storage hopper and an oscillating feeder with touchscreen control.** The entire unit is started at the push of a button and can be operated intuitively via touchscreen, buttons and foot pedal. All functions are controlled by a touchscreen, which ensures a good overview and easy operation. The filling weight can be keyed in quickly and easily and the dosing process is triggered by a foot pedal. This allows the customization and monitoring of the amount of pellets.

### Specifications

Re-filling capacity:	up to 2'000 kg/h (4'400 lb/h)
Dosing accuracy:	+/- 0.1 kg (0.2 lb) at 3kg (6.6 lb) filled units
Voltage:	400V/ 3AC/ 50Hz/ N/ PE 24V control voltage
Connected power:	approx. 2.5 kW (3.4 HP)
Electrical protection:	min. 20A/ max. 32A
Pneumatic system supply:	min. 6 bar (87 psi), dry, oil free
Ambient temperature:	+ 5°C up to + 35°C (41°F up to 95°F)
Dimensions (L x W x H):	approx. 3'860 mm x 2'300 mm x 3'770 mm (4'850 mm tipping height) approx. 152 in x 90.5 in x 148 in ( 191 in tipping height)
Weight:	approx. 3'900 kg (8'600 lb)
Requirements installation site:	min. C20/25 concrete (uncracked) min. 200mm (7.9 in) foundation thickness
Connectivity and remote access:	LAN
Base media:	3, 6, 10, 16 mm (1/8, 1/4, 3/8, 5/8 in) dry ice pellets
Dry ice supply:	ASCO AT440 or AT240W container (variable)
Container carrying capacity:	max. 800 kg (1764 lb)
Storage hopper volume:	approx. 1 m <sup>3</sup> (35 cu ft)

## ASCO Dry Ice Refilling System ARS: Function and applications

Thanks to the ASCO Dry Ice Refilling System ARS, dry ice pellets can be transfilled from large storage containers directly into smaller containers or smaller boxes and dosed by weight. This is particularly helpful when cold chains must not be interrupted and goods are to be sent under cryogenic conditions. For the filling of the dry ice pellets, individually storable presettings are available that define the amount of the pre-filling and main filling with dry ice. This means that goods can be covered all around with the cooling medium. A visual message on the display confirms that the preset filling quantity has been reached by means of an integrated scale.

The full integration of the system into the control system offers absolute system security, as all functions are centrally displayed and monitored. The automatic container refilling system for dry ice pellets is designed as standard for the ASCO AT440 and AT240W dry ice containers but can also be loaded with other storage containers. The integration of the refilling system into fully automatic dry ice production on conveyor belts can be freely selected (supply and removal of the containers including filling).



**Ergonomic operation**

- Automatic filling process
- Automatic discharge
- Safety barriers with safety switch
- Simultaneous refilling and dosing possible



**Central control**

- 7" Touchscreen
- Foot pedal for dosing
- Switches for manual mode

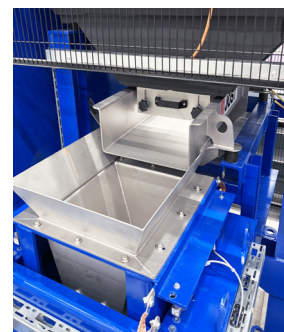

**Refilling system**

- Fill level monitoring
- Stepless dosing with oscillating feeder
- Insulated storage bunker made in stainless steel

## ASCO Dry Ice Refilling System ARS: Key features

- **Higher-level control** - regulates the entire process, the dry ice prefilling, the filling of the oscillating feeder, the fill level monitoring and the dosage of the dry ice pellets according to weight.
- **SIEMENS PLC with 7" HMI Colour-Touchscreen** - 7" Touchscreen with different access levels, adjustable parameters as well as set and reached filling quantity. Including LAN remote access.
- **Foot pedal for actuating the filling process** - the preset filling quantity is conveniently triggered by the foot pedal and enables two-handed handling or organization of the filling process.
- **Integrated fill level monitoring** - if the required dry ice pellet quantity in the storage hopper falls below the required level, the machine automatically goes into a waiting mode until the correct fill level is reached again. If the storage hopper is full, the lifting unit remains in waiting position until it can be filled again. An overfilling of the storage hopper is not possible.
- **High process reliability** - optimal process monitoring using the integrated load cell ensures optimal performance and high process reliability. The unit is not designed for dry ice storage and can be fully discharged at the push of a button.
- **Integrated access security and protection** - Safety doors with safety switch according to EC 2006/42/EC Machinery Directive.

Pos. 001

### ASCO Dry Ice Refilling System ARS CE

For precise dosing and refilling of dry ice pellets in various containers and shipping boxes.

Consisting of lifting and tilting unit, insulated storage hopper with scale, stepless oscillating feeder and integrated central control unit.

Without transport conveyor system.

part no. 901501



# ASCO Dry Ice Blasting Technology

## General Information

### What is CO<sub>2</sub>?

Carbon dioxide or CO<sub>2</sub> is an odourless, inert gas approximately 1½ times heavier than air and 0.03 % is normally present in the earth's atmosphere. It is also found in great quantities in volcanoes, earth cracks, other sources and in the metabolism of plants, animals, and human beings.

Commercially, CO<sub>2</sub> can be recovered as a by-product from various chemical industries and is usually stored in a tank after recovery. Carbon dioxide can exist in three forms:

- in gaseous form (for the beverage and food industries)
- In liquid form (in a storage tank under pressure)
- in solid form (called dry ice, for cooling, blasting etc.)

### What is Dry Ice?

Dry ice is produced from liquid carbon dioxide. Inside a pelletizer, the liquid carbon dioxide is expanded under controlled conditions. This physical change forms dry ice snow. This snow is then pressed through an extruder plate into round, hard pellets (elongated grains with a diameter of 3 mm or 1.7 mm) (0.12 in or 0.07 in). Dry ice has a temperature of approx. -79°C.



### Cleaning Method

The ASCO Dry Ice Blasting machine accelerates the pellets with compressed air to a speed of approx. 300 m/s (984.25 ft/s). The pellets hit the object to be cleaned. The surface is shock-frozen in a fraction of a second. Due to the cracking of the surface, the pellets can reach under the dirt and remove it using their kinetic energy. Immediately after impact, the pellets sublime without leaving any moisture behind. Since the hardness of the pellets is only approx. 2 Mohs, the cleaning is virtually non-abrasive, and the surface quality is maintained.

<p><b>The thermo shock</b> As a result of the sudden and intense temperature shock on the surface, the coating or impurity contracts.</p>	<p><b>The cracking</b> As a result of the contraction the coating cracks and the material becomes brittle due to the cold.</p>	<p><b>The cleaning</b> The dry ice pellets hit the surface with great speed and remove the detached coating and clean the surface material.</p>

# General Information

## Where can this unique cleaning method be applied?

The ASCO Dry Ice Cleaning Technology is a gentle non-abrasive cleaning method suitable on almost all surfaces especially for mold cleaning in foundries, in the tire manufacturing, the plastic injection molding industry and the cleaning of machinery in general but especially in the food manufacturing process. Basically, it easily removes all materials, which react to differences in temperature or kinetical energy or a combination of both of them like release agent, plastic, synthetic and food residues, foam (e.g. PU), paint, varnish, adhesives, wax, bitumen, etc. without damaging or altering the surface. Another benefit is that it reduces the amount of waste material considerably.

## What are the advantages over other cleaning methods?

Wherever conventional cleaning methods cause long and expensive down-time of equipment, machinery and/or labor, this modern technique considerably reduces down-time. The often costly and intensive after-treatment of the cleaned surfaces is no longer necessary.

Another major benefit is that the removal and disposal of contaminated blasting media is completely eliminated as the dry ice pellets simply sublimate back to the atmosphere.

### Increased productivity – cost saving

- Since this cleaning technology is dry and non-abrasive, it can be applied directly onto the object to be cleaned. Thus down time can be reduced to a minimum. Time is saved and cooling down or the other way around heating up of tools is obsolete.
- Cleaning of machinery, tools, molds, conveyors etc. can be done without removing them from the machine.
- Cleaning even during the running process is no problem.
- Another benefit is that it reduces the amount of waste material considerably, especially for hazardous waste.

### Increased quality – non-abrasive

- The hardness of dry ice pellets can be compared with the hardness of chalk. Therefore the surface structure of the cleaning surface is not being damaged nor altered in any way.
- A gentle but nevertheless effective cleaning technology.
- Suitable for very sensitive and fine-structured surfaces (CD-stamp, wafer, polished surfaces)
- Fine edges and delicate structures remain unchanged.
- Non scrubbing (Steel brushes, scraper)

### Dry

- Cleaning with dry ice is a dry and non-conductive cleaning process.

### Health

- By eliminating the use of solvents and hazardous chemicals the dry ice cleaning method is safe for people and environment.

### Environment friendly

- The dry ice sublimates on impact onto the surface. Only the removed contaminant remains. It is not necessary to dispose the cleaning media – it reduces waste dramatically!
- No sewage – or cleaning and filtration of waste water
- No contamination by hazardous additives, chemicals etc.
- No remains of the cleaning media
- Non toxic
- No use of water, therefore no breeding ground for germs

### Powerful – a fast cleaning technology

- Powerful – hardly no loss of pressure by extending the hoses up to 75 m (246 ft) length and 35 m (115 ft) height.
- Direct cleaning for instance onto hot molds without having to cool them down first.
- Normally, no disassembling of the machine parts is necessary.
- ASCO dry ice blasting is the perfect solution for many different applications in various industries.

### Compact and mobile

- The equipment is light, mobile, maintenance-free, reliable and easy to operate.

# Necessary Equipment

## ASCO Dry Ice Blasting Unit



Depending on the application, the appropriate dry ice blasting unit can be chosen. Our range consists of six different **ASCO** models with different performances and features.

Various nozzles (barrel, flat and angled nozzles) with different air flows are available to allow even higher flexibility.

## ASCO Dry Ice Pelletizer



Dry ice pellets with a diameter of 3 mm (0.12 in) are standardly used for the dry ice blasting technology. This size of dry ice can usually be bought from a local gas company. To ensure a ready supply of high quality pellets, having in-house your own dry ice machine is a definite advantage.

## ASCO Air Compressor



In order to give the dry ice pellets the necessary speed and blasting effect, compressed air must be fed to the blasting unit.

Depending on the application, compressed air between 2-20 bar (29-290 psi) and an air flow between 1-15 m<sup>3</sup>/min (35.3-529.7 ft<sup>3</sup>/min) is required.

# Technical Specifications of Blasting Air

To reach a certain cleaning performance, a corresponding air pressure and volume is needed. Generally, the more air volume is used, the more powerful the units are. **ASCO** Dry Ice Blasting Units have enough power for each application, thus minimising production down times.

Below please find a list showing the standard air consumption of each unit. These figures are valid for the use with the standard nozzle and can vary if other nozzles are used:

Working pressure	Air consumption (m <sup>3</sup> /min.)		
	ASCOJET 1208	ASCOJET 1701	ASCOJET 1708
2 bar (29 psi)	1.1 (39 ft <sup>3</sup> /min)	-	-
3 bar (44 psi)	1.6 (57 ft <sup>3</sup> /min)	-	-
4 bar (58 psi)	2.1 (75 ft <sup>3</sup> /min)	3.7 (131 ft <sup>3</sup> /min)	3.7 (131 ft <sup>3</sup> /min)
6 bar (87 psi)	2.9 (103 ft <sup>3</sup> /min)	4.6 (162 ft <sup>3</sup> /min)	4.6 (162 ft <sup>3</sup> /min)
7 bar (102 psi)	3.5 (124 ft <sup>3</sup> /min)	5.0 (177 ft <sup>3</sup> /min)	5.0 (177 ft <sup>3</sup> /min)
8 bar (116 psi)	4.0 (142 ft <sup>3</sup> /min)	5.4 (191 ft <sup>3</sup> /min)	5.4 (191 ft <sup>3</sup> /min)
10 bar (145 psi)	5.1 (181 ft <sup>3</sup> /min)	6.2 (219 ft <sup>3</sup> /min)	6.2 (219 ft <sup>3</sup> /min)

**\*OHP additive:** Combination blasting with blasting gun additive OHP (Blasting nozzle additive)

**\*HP:** Double hose system with blasting gun HP (High Performance Barrel Nozzle HP255)

**Note:** These figures are valid for each unit equipped with its standard gun. If the above consumption rates do not suit your requirements, please inform us when asking for a quote.

In order to ensure the perfect function of our blasting equipment, **ISO-standard 8573-1 must be complied within the following areas:**

	Class	Max. target value
Oil content	Class 3	Max. residual oil content 1 mg/m <sup>3</sup>
Particle size and density	Class 3	Max. particle size 5µm, density 5 mg/m <sup>3</sup>
Pressure dew point	Class 4	Max. residual water content 5.953 g/m <sup>3</sup> and pressure dew point of +3 °C

# CO<sub>2</sub> Revert Recovery System



When dry ice is produced the conversion rate from liquid CO<sub>2</sub> to dry ice is approx. 40-45%. With a CO<sub>2</sub> Revert Recovery System, however, most of the otherwise lost CO<sub>2</sub> can be recovered to give a final conversion rate of approx. 90-95%. It goes without saying that with such a CO<sub>2</sub> Recovery System the dry ice production costs can be reduced enormously.

ASCO offers several CO<sub>2</sub> Revert Recovery Systems for its different dry ice pelletizers with a recovery capacity from 70 to 2'500 kg (154 to 5'500lb) CO<sub>2</sub> gas per hour. ASCO Dry Ice Pelletizers are made so that a CO<sub>2</sub> recovery system can easily be connected. We will be pleased to help you choose the right CO<sub>2</sub> Revert Recovery System.

- reducing dry ice costs up to 50 % by recovering the normally „lost“ CO<sub>2</sub> gas
- automatic (PLC) operation
- compact design
- skid mounted for easy installation (ASCO RRS 300 and ASCO RRS 560)
- heavy duty construction

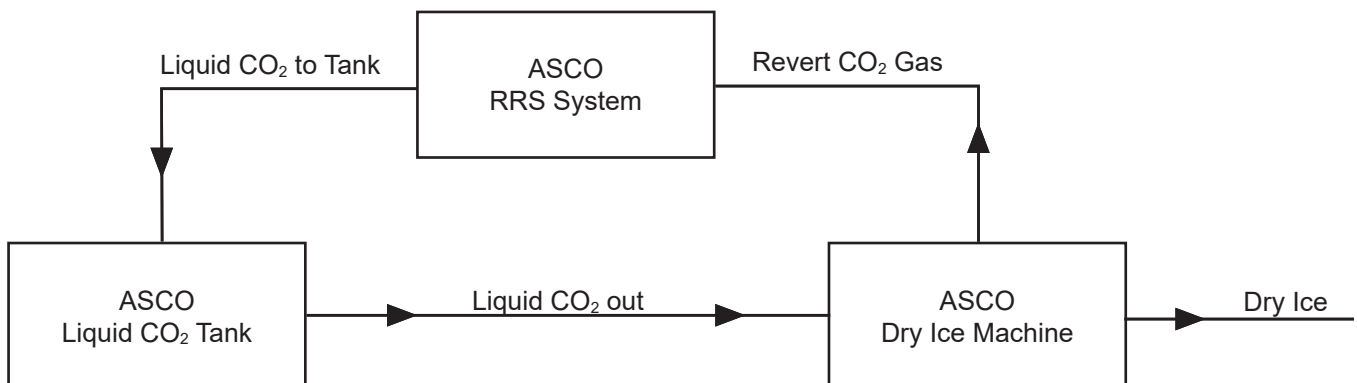



# Overview ASCO Dry Ice Blasting System

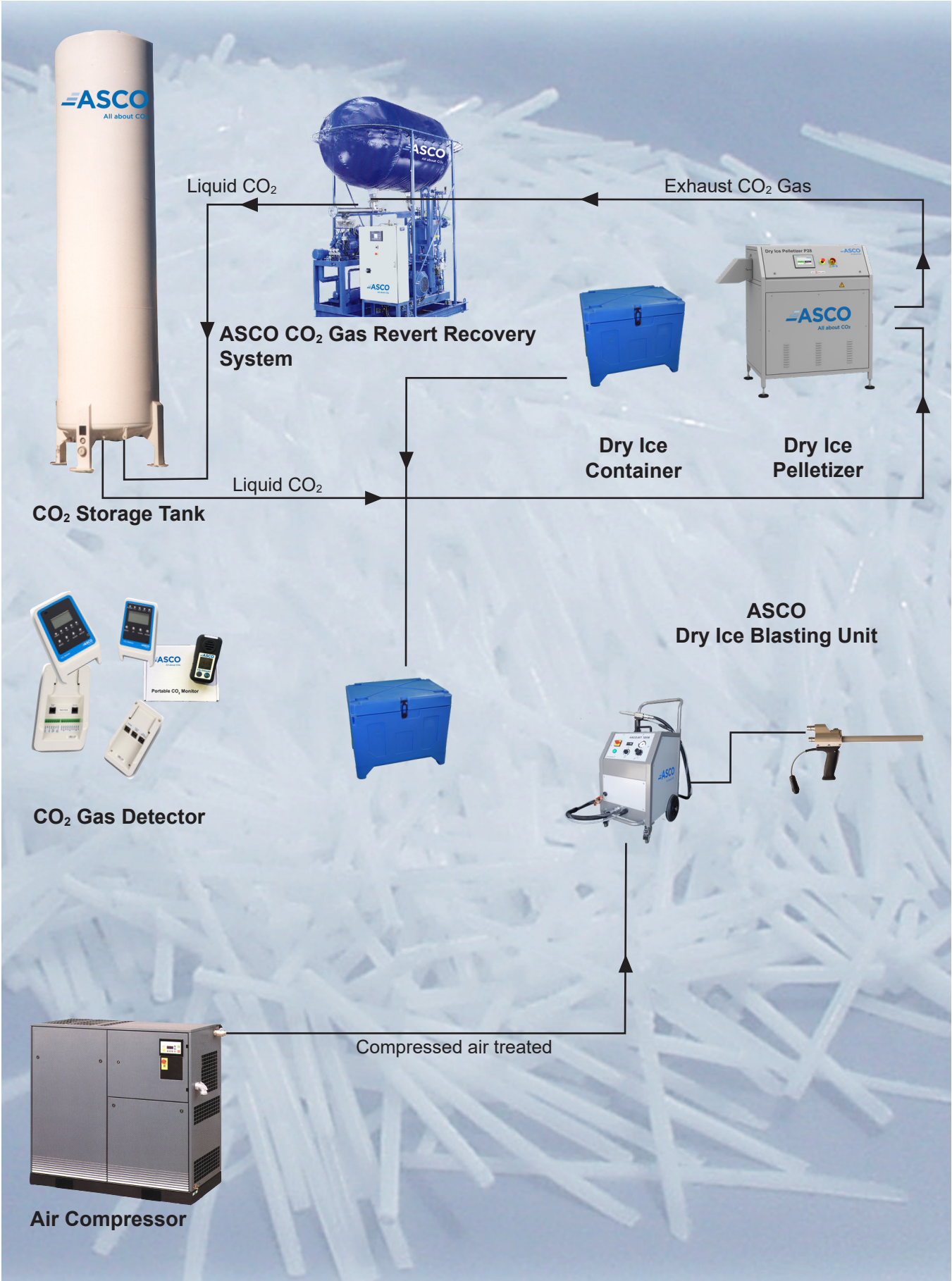

# Applications

Nowadays, the **ASCO** Dry Ice Blasting Technology is used in most industries, specially where a dry, environmentally friendly, powerful and non-abrasive cleaning method is required. Below is an extract from our application list outlining the most common uses. Please call us if more information about applications is required.

Aircraft	Pharmaceutical industry
Automotive industry	Power plants
Chemical industry	Printing industry
Cleaning companies/ Facility management	PU-production
Electric components	Repair of fire damage
Food industry	Rubber industry
Foundries	Ship building
Injection moulding	Tyre manufacturing
Paper industry	etc.

Dry ice blasting technology can be used wherever paint, varnish, resin, wax, oil, grease, release agent etc. has to be removed without damaging the surface. Even delicate parts like switch boards and other electric components can be cleaned.

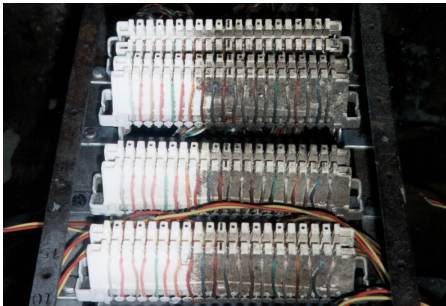

Cleaning of a switch board of a national Telecommunication Company. In this way short circuits can be avoided.

Cleaning of an industrial fan in a hotel kitchen. Due to the thick layer of greasy residues, the fan no longer operated efficiently.



Dry ice cleaning in the paper industry: The removal of paper residues and lubrication oil from paper production machines also eliminates burn marks.

# Applications

## Foundries



Cleaning of a hot ingot mould without dismantling

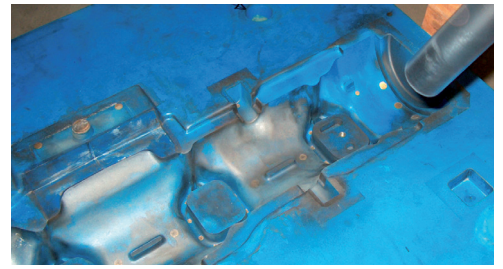

Core box cleaning in a grey iron foundry

## Plastics industry



Cleaning of a mould in PU-production

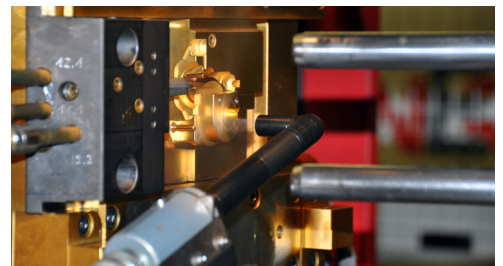

Cleaning of injection moulds

## Rubber industry



Cleaning of moulds for the production of tennis balls

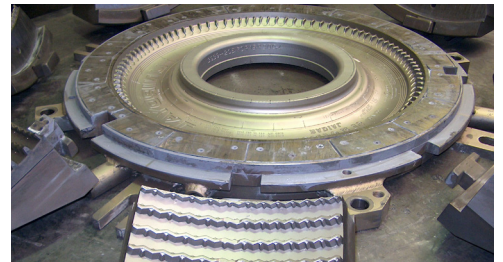

Cleaning of tyre moulds

## Food industry



Removal of cheese and tomato residues in a pizza bakery

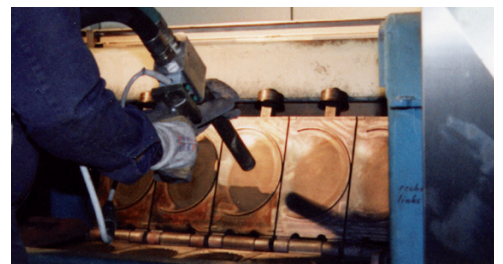

Cleaning of a hot waffle iron

# Applications

## Printing industry

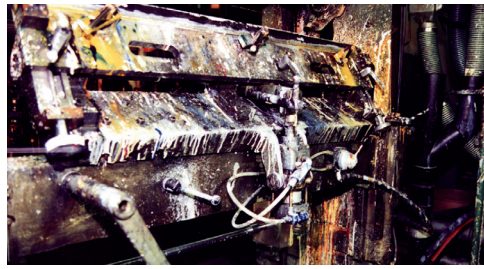

Printing machine before ...

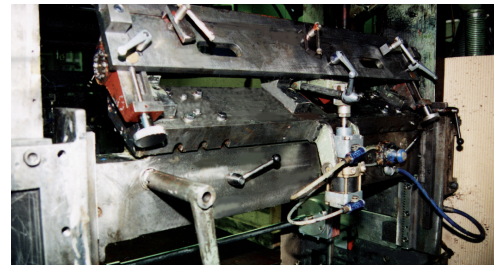

... and after cleaning

## Façade cleaning



Stonewall before and after cleaning



Wooden façade before and after cleaning

## Fire damage



Fire damage before ...

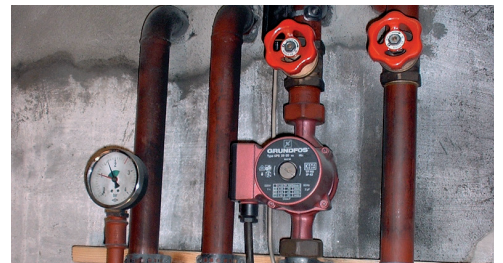

... and after cleaning

# More than just a Cleaning Method

In the field of the dry ice blasting technology ASCO has specialised in offering individual and complete solutions for the specific needs of customers. These individual solutions can start with a single dry ice blasting machine. ASCO's policy is then to help and advise its customers on how to achieve their best dry ice cleaning solution.

Solutions can include:

- **development of an in-house dry ice production**
- **noise control booths**
- **automated dry ice cleaning**
- **safety concepts**
- **customized products like special blasting guns or nozzles**
- **etc.**

**ASCO Dry Ice Blasting is therefore a cleaning method that can be individually tailored to increase quality and flexibility in your daily working process.**



Automated mould cleaning in the plastics industry. This robot technology can also be applied to cleaning other moulds like ingot moulds and core boxes.

Automated spraying on and removal of release agent in the PU-production: The robot can be programmed for spraying on the release agent and for removing it with dry ice.



# Dry Ice Blasting Unit

## ASCOJET 1208

complete (fully adjustable)

part no. 900960



The **ASCOJET 1208** features a new modern frame design and self-explanatory pictogram. This powerful blasting machine is very easy to use and is particularly suitable for use in industries.

The newly integrated grounding roll and the protective grating in the pellet hopper guarantee safe handling during the blasting process.

### Powerful and very handy blasting gun:

Thanks to a **quick connect coupling** the gun can be attached to the blasting unit very easily.

Increased security thanks to the **locking pin**, which makes a sudden opening of the locking mechanism of the nozzle impossible.

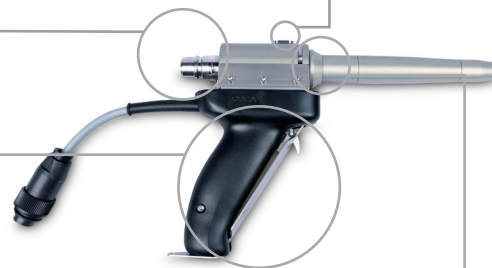

The **ergonomic gun handle** ensures very easy handling and comfortable operation when blasting over longer periods. The new developed safety button is ideal for left and right-hander.

A **quick exchange system** allows nozzles to be changed within seconds without any tools.

### Specifications

Material:	frame and cover sheets made of powder-coated steel
Dimensions (L x W x H) incl. wheels & folded handle:	635 x 491 x 872-1'220 mm (variable) (25 x 20 x 35-48 in)
Weight empty:	approx. 62 kg (136 lb)
Content of pellet hopper:	approx. 9 kg (20 lb)
Blasting pressure:	0 - 10 bar (0 - 145 psi) (adjustable)
Dry ice consumption:	20 - 40 kg/h (44 - 88 lb/h) (stepless)
Max. power consumption:	500 W (0.7 HP) nominal
Voltage:	230 V, 50 Hz, 1 Ph (other voltages on request)
Inlet hose connection:	3/4" BSP female 3/4" Claw coupling fitted

## ASCOJET 1208: Special features

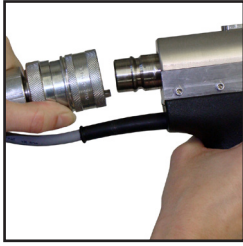

Powerful and handy blasting gun with quick connect coupling

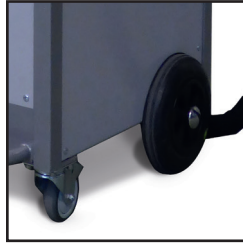

Highly manoeuvrable



Quick connect coupling at blasting hose



Lightweight and compact



Integrated holding device for hose



Vertically adjustable handle for easy handling

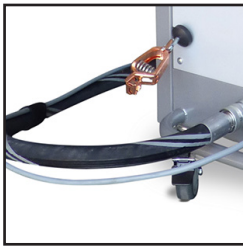

Integrated grounding wire for more safety



Insulated pellet hopper with 9 kg (20lb) capacity



Control panel for easy overview

## ASCOJET 1208: Standard scope of supply

Pos. 001

### Blasting gun OHS6

Standard for the ASCOJET 1208

Length: 26 cm (10.2 in)

Weight: 1.0 kg (2.2 lb)

Blasting pressure: 0 - 10 bar (0 - 145 psi)

(Blasting gun OHS6 V2016 without nozzle part no. 4064771)

including the corresponding blasting nozzle

### High performance barrel nozzle 707.15/12

Standard for the blasting gun OHS

Powerful nozzle with low air consumption

Outlet opening: approx. Ø 12 mm (0.5 in)

Length: 15 cm (6 in)

Inner diameter: 7 mm (0.3 in)

OHS

part no. 4063745



part no. 4047321



Pos. 002

### Hose assembly 5m for OHS gun ID16mm (197 in ID 0.6 in)

Standard for the ASCOJET 1208, can also be used as an extension of the hose assembly incl. control cable, grounded

OHS

part no. 4047104



## ASCO 1208: Standard scope of supply

Pos. 002

### Claw coupling with 19 mm (3/4 ") male thread

For fast connection and disconnection of the air line to the blasting equipment

Already mounted on the unit.

part no. 4045949



Pos. 003

### Power cable 10 m (32 in)

part no. 4053647

## ASCO 1208 tool case: Scope of supply

Pos. 001

### Tool case ASCOJET 1208

Tool case complete  
(contains below articles pos. 002 - 007)

OHS  
OHP

part no. 4064567



Pos. 002

### Tool case ASCOJET 1208 empty

Empty tool case with matching insert

OHS  
OHP

part no. 4064570



Pos. 003

### Barrel nozzle 707.09/10

Thanks to an inner diameter of only 7 mm (0.3 in) the barrel nozzle has a very economical air consumption but is nevertheless powerful

Outlet opening: approx. Ø 10 mm (0.4 in)

Length: 9 cm (3.5 in)

Inner diameter: 7 mm (0.3 in)

OHS  
OHP

part no. 4047228



Pos. 004

### Flat nozzle 709.23/45

Powerful nozzle suitable for blasting large areas

Outlet opening: approx. 45 x 3.5 mm (1.77 x 0.14 in)

Length: 23 cm (9 in)

Inner diameter: 9 mm (0.4 in)

OHS  
OHP

part no. 4047216



Pos. 005

### Angled nozzle 708.28/10/45°

A powerful nozzle for confined spaces with very low air consumption

Outlet opening: approx. Ø 10 mm (0.4 in)

Length: 28 cm (11 in)

Inner diameter: 8 mm (0.3 in)

OHS  
OHP

part no. 4047222





## ASCO 1208 tool case: Scope of supply

Pos. 006

### Angled nozzle 708.25/10/75°

A powerful nozzle for confined spaces with very low air consumption

Outlet opening: approx. Ø 10 mm (0.4 in)

Length: 25 cm (10 in)

Inner diameter: 8 mm (0.3 in)

OHS  
OHP

part no. 407223



Pos. 007

### Lighting kit for dry ice blasting gun

Compact torch

LED light 160 lumen, 160 cm (63 in)

Up to 25 hours battery life (3 x 1.5V AAA)

Batteries not included in scope of supply

Length: 10.6 cm (4.2 in)

Weight: 120 g (0.4 lb)

OHS  
OHP  
HP

part no. 4064129



## ASCOJET 1208: Options

Pos. 001

### Barrel nozzle 707.15/12

Thanks to an inner diameter of only 7 mm (0.3 in) the barrel nozzle has a very economical air consumption but is nevertheless powerful

Outlet opening: approx. Ø 12 mm (0.5 in)

Length: 15 cm (6 in)

Inner diameter: 7 mm (0.3 in)

OHS  
OHP

part no. 4047321



Pos. 002

### Pellet cutter OHS

For sensitive blasting applications

With safety quick connect coupling, 2.5 m (8.2 ft) hose and control cable, grounded

OHS

part no. 4047026



Pos. 003

### Protective sleeve for one hose system 165 mm (6.5 in)

To protect the control cable and blasting hose from dirt and damages

Available in meters

OHS  
OHP

part no. 4047265



Pos. 004

### Protective hood for ASCOJET 1208

The newly developed hood for our blasting equipment protects the control elements from contamination. The transparent cover can be opened for easy view on and access to the operation elements. For cleaning the hood can easily be taken off

part no. 4064528



## ASCOJET 1208: Options

Pos. 005

### Spare parts kit ASCOJET 1208

Includes a recommended selection of spare parts to ensure constant operation.

part no. 4064527

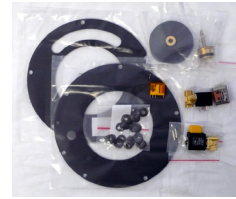

Sample image

Pos. 006

### Compressed air hose 7.5 m (24.6 ft) / ID 25 mm (1 in)

Connecting hose between air compressor and dry ice blasting machine, incl. claw coupling and safety ring for fast and easy connection / disconnection

Material: Fabric hose / metal

Dimension: 7.5 m (24.6 ft)

Weight: 2.4 kg (5.3 lb)

part no. 4045955



Pos. 007

### Nozzle extension 700.150 OHP/OHS

Modular nozzle extension for OHS and OHP dry ice blasting guns with a total length of up to 1.5 m (59 in) with nozzle

Length 1: 455 mm (18 in) without nozzle

Length 2: 580 mm (23 in) without nozzle

Length 3: 835 mm (33 in) without nozzle

Length 4: 960 mm (38 in) without nozzle

Length 5: 1340 mm (53 in) without nozzle

Weight in full length: 1.50 kg (3.3 lb)

Inner diameter: 10 mm (0.4 in)

Material: aluminium

OHS  
OHP

part no. 4046018



Pos. 008

### Nozzle extension 700.62 OHP/OHS

Modular for nozzle extension for OHS and OHP dry ice blasting guns with a length of 668 mm (26.3 in)

Weight: 0.6 kg (1.3 lb)

Inner diameter: 10 mm (0.4 in)

Material: aluminium

OHS  
OHP

part no. 4063373



# Dry Ice Blasting Unit

## ASCOJET 1701

complete (fully adjustable)

part no. 901023



The **ASCOJET 1701** is a compact, mobile dry ice blasting unit featuring a handy one hose system which has been specially developed to maintain efficient cleaning with contaminants which are harder to remove.

This powerful unit is suitable for industrial end users like foundries, tyre manufacturers, food industry and printing industry who require high performance and easy handling.

### Powerful and handy blasting gun:

Thanks to a **quick connect coupling** the gun can be attached to the blasting unit very easily.

Increased security thanks to the **locking pin**, which makes a sudden opening of the locking mechanism of the nozzle impossible.



An **quick exchange system** allows nozzles to be changed within seconds without any tools.

The **ergonomic gun handle** ensures very easy handling and comfortable operation when blasting over longer periods. The new developed safety button is ideal for left and right-hander.

### Specifications

Material:	frame and cover sheets made of powder-coated steel
Dimensions (L x W x H) incl. wheels & handle:	752 x 608 x 1'103 mm (30 x 24 x 44 in)
Weight empty:	approx. 104 kg (229 lb)
Content of pellet hopper	approx. 23 kg (51 lb)
Blasting pressure:	0 - 10 bar (0 - 145 psi) (adjustable)
Dry ice consumption:	25 - 80 kg/h (55 - 176 lb/h) (stepless)
Max. power consumption:	600 W (0.80 HP) nominal
Voltage:	230 V, 50 Hz, 1 Ph (other voltages on request)
Inlet hose connection:	3/4" BSP female 3/4" Claw coupling fitted

## ASCOJET 1701: Special features

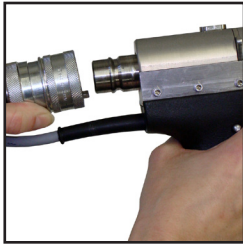

Powerful and handy blasting gun with quick connect coupling



Highly manoeuvrable



Integrated holding device for hose



Lightweight and compact

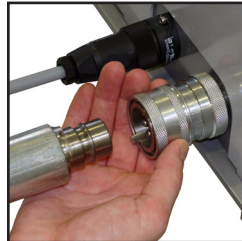

Quick connect coupling at blasting hose



Box for gun, nozzles and tools

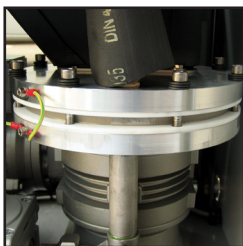

Distributor unit for pulsation-free blasting



Insulated pellet hopper with 23kg (50lb) capacity



Control panel for easy overview

## ASCO 1701: Standard scope of supply

### Pos. 001

#### Blasting gun OHP

Standard for the ASCOJET 1701

Length: 33 cm (12.9 in)

Weight: 1.05 kg (2.3 lb)

Blasting pressure: 0 - 10 bar (0 - 145 psi)

(Blasting gun OHP4 without nozzle part no. 4064749)

including the corresponding blasting nozzle

#### High performance barrel nozzle 709.23/15

Standard for the blasting gun OHP

Most powerful nozzle of the ASCOJET single-hose system

Outlet opening: approx. Ø 15 mm (0.6 in)

Length: 23 cm (9 in)

Inner diameter: 9 mm (0.4 in)

part no. 4063749



OHP

part no. 4047144



### Pos. 002

#### Hose assembly 7.5 m (24.6 ft) for OHP gun

Standard for the ASCOJET 1701, can also be used as an extension of the hose assembly incl. control cable, grounded.

part no. 4045987



OHP

## ASCO 1701: Standard scope of supply

Pos. 002

### Claw coupling with 19 mm (3/4") male thread

For fast connection and disconnection of the air line to the blasting equipment

Already mounted on the unit.

part no. 4045949



Pos. 003

### Power cable 10 m (32 in)

part no. 4053647

## ASCO 1701 tool case: Scope of supply

Pos. 001

### Tool case ASCOJET 1701 / 1708

Tool case complete  
(contains below articles pos. 002 - 008)

OHP

part no. 4064572



Pos. 002

### Tool case ASCOJET 1701 / 1708 empty

Empty tool case with matching insert

OHP

part no. 4064575



Pos. 003

### High performance barrel nozzle 709.17/14

Powerful and handy nozzle

Outlet opening: approx. Ø 14 mm (0.5 in)

Length: 17 cm (6.7 in)

Inner diameter: 9 mm (0.4 in)

OHP

part no. 4045402



Pos. 004

### Barrel nozzle short 709.09/11

Powerful nozzle to clean in narrow spaces

Outlet opening: approx. Ø 11 mm (0.4 in)

Length: 9 cm (3.5 in)

Inner diameter: 9 mm (0.4 in)

OHP

part no. 4045403



## ASCO 1701 tool case: Scope of supply

Pos. 005

### Barrel nozzle special 709.42/15

part no. 4047141

The nozzle is designed to allow for a comfortable working position of the person in charge and is very powerful

Outlet opening: approx. Ø 15 mm (0.6 in)  
Length: 42 cm (16.5 in)  
Inner diameter: 9 mm (0.4 in)

OHP



Pos. 006

### Angled nozzle 708.28/10/45°

part no. 4047222

A powerful nozzle for confined spaces with low air consumption

Outlet opening: approx. Ø 10 mm (0.4 in)  
Length: 28 cm (11 in)  
Inner diameter: 8 mm (0.3 in)

OHS  
OHP



Pos. 007

### Flat nozzle 709.23/45

part no. 4047216

Powerful nozzle suitable for blasting large areas

Outlet opening: approx. 45 × 3.5 mm (1.77 x 0.14 in)  
Length: 23 cm (9 in)  
Inner diameter: 9 mm (0.4 in)

OHS  
OHP



Pos. 008

### Lighting kit for dry ice blasting gun

part no. 4047129

Compact torch  
LED light 160 lumen, 160 cm (63 in)  
Up to 25 hours battery life (3 x 1.5V AAA)  
Batteries not included in scope of supply  
Length: 10.6 cm (4.2 in)  
Weight: 120g (0.4 lb)

OHS  
OHP  
HP



## ASCOJET 1701: Options

Pos. 001

### Angled nozzle 709.28/11/45°

part no. 4047219

A powerful nozzle for very confined spaces and difficult to reach spots

Outlet opening: approx. Ø 11 mm (0.4 in)  
Length: 28 cm (10.9 in)  
Inner diameter: 9 mm (0.4 in)

OHP



Pos. 002

### Angled nozzle 709.25/11/75°

part no. 4047220

A powerful nozzle for very confined spaces and difficult to reach spots

Outlet opening: approx. Ø 11 mm (0.4 in)  
Length: 25 cm (9.8 in)  
Inner diameter: 9 mm (0.4 in)

OHP



## ASCOJET 1701: Options

Pos. 003

### Pellet cutter OHP

For sensitive blasting applications

With safety quick connect coupling, 2.5 m (8.2 ft) hose and control cable, grounded

OHP

part no. 4047257



Pos. 004

### Converter coupling ASCOJET 1701 - 1208

This converter coupling makes it possible that the OHS gun with the corresponding blasting hose of the ASCOJET 1208 can be connected to the ASCOJET 1701

Length: 7.8 cm (3.0 in)

Weight: 0.2 kg (0.4 lb)

Outlet opening: approx. Ø34 mm (1.3 in)

OHS

part no. 4047040



Pos. 005

### Blasting gun OHS

Standard for the ASCOJET 1208

Length: 26 cm (10.2 in)

Weight: 1.0 kg (2.2 lb)

Blasting pressure: 0 - 7 bar (0 - 102 psi)

OHS

part no. 4063745



Including the corresponding blasting nozzle

### High performance barrel nozzle 707.15/12

Standard for the blasting gun OHS

Powerful nozzle with low air consumption

Outlet opening: approx. Ø 12 mm (0.5 in)

Length: 15 cm (5.9 in)

Inner diameter: 7 mm (0.3 in)

part no. 4047321



Pos. 009

### Hose assembly 5 m (16.4 ft) for OHS gun

Standard for the ASCOJET 1208, can also be used as an extension of the hose assembly incl. control cable, grounded

OHS

part no. 4047104



Pos. 007

### Nozzle extension 700.150 OHP/OHS

Modular nozzle extension for OHS and OHP dry ice blasting guns with a total length of up to 1.5 m (59 in) with nozzle

Length 1: 455 mm (18 in) without nozzle

Length 2: 580 mm (23 in) without nozzle

Length 3: 835 mm (33 in) without nozzle

Length 4: 960 mm (38 in) without nozzle

Length 5: 1340 mm (53 in) without nozzle

OHS  
OHP

part no. 4046018



Weight in full length: 1.50 kg (3.3 lb)

Inner diameter: 10 mm (0.4 in)

Material: aluminium

## ASCOJET 1701: Options

Pos. 008

### Barrel nozzle 707.09/10

Thanks to an inner diameter of only 7 mm (0.27 in) the barrel nozzle has a very economical air consumption but is nevertheless powerful

Outlet opening: approx. Ø 10 mm (0.4 in)  
Length: 9 cm (3.5 in)  
Inner diameter: 7 mm (0.3 in)

OHS  
OHP

part no. 4047228



Pos. 009

### Barrel nozzle 707.15/12

Thanks to an inner diameter of only 7 mm (0.3 in) the barrel nozzle has a very economical air consumption but is nevertheless powerful

Outlet opening: approx. Ø 12 mm (0.5 in)  
Length: 15 cm (6 in)  
Inner diameter: 7 mm (0.3 in)

OHS  
OHP

part no. 4047321



Pos. 010

### Angled nozzle 708.25/10/75°

A powerful nozzle for confined spaces with low air consumption

Outlet opening: approx. Ø 10 mm (0.4 in)  
Length: 25 cm (9.8 in)  
Inner diameter: 8 mm (0.3 in)

OHS  
OHP

part no. 4047223



Pos. 011

### Nozzle extension 700.62 OHP/OHS

Modular for nozzle extension for OHS and OHP dry ice blasting guns with a length of 668 mm (26.3 in)

Weight: 0.6 kg (1.3 lb)  
Inner diameter: 10 mm (0.4 in)  
Material: aluminium

OHS  
OHP

part no. 4063373



Pos. 012

### Spare parts kit ASCOJET 1701

Includes a recommended selection of spare parts to ensure constant operation.

part no. 4047140



Sample image

Pos. 013

### Compressed air hose 7.5 m (24.6 ft) / ID 25 mm (1 in)

Connecting hose between air compressor and dry ice blasting machine, incl. claw coupling and safety ring for fast and easy connection / disconnection  
Material: Fabric hose / metal  
Dimension: 7.5 m (24.6 ft)  
Weight: 2.4 kg (5.3 lb)

part no. 4045955





## ASCOJET 1701: Options

Pos. 014

### Protective sleeve one hose sys. 165 mm (6.5 in)

To protect the control cable and blasting hose from dirt and damages

Available per meter

part no. 4047265



Pos. 015

### Protective hood for ASCOJET 1701/1708

The newly developed hood for our blasting equipment protects the control elements from contamination. The transparent cover can be opened for easy view on and access to the operation elements. For cleaning the hood can easily be taken off

part no. 4065213



# Dry Ice Blasting Unit

## ASCOJET 1708 Combi Blaster

complete (fully adjustable)

part no. 900480



The **ASCOJET 1708 Combi Blaster** is the first ASCO dry ice blasting unit which allows the use of an additional blasting material in the blasting flow and therefore offers the best combination of gentle cleaning with dry ice pellets and the additional abrasive effect of a carefully selected additive.

Powerful, handy, minimal secondary pollution and reduced noise emission thanks to a low air consumption - The **ASCOJET 1708 Combi Blaster** is perfectly suitable for industrial end users of all kinds.

### Powerful and handy blasting gun:

Thanks to a **quick connect coupling** the gun can be attached to the blasting unit very easily.

Increased security thanks to the **locking pin**, which makes a sudden opening of the locking mechanism of the nozzle impossible.



The **ergonomic gun handle** ensures very easy handling and comfortable operation when blasting over longer periods. The newly developed safety button is ideal for left and right hander.

A **quick exchange system** allows nozzles to be changed within seconds without any tools.

### Specifications

Material:

Dimensions (L x W x H) incl. wheels & handle:

Weight empty:

Content of pellet hopper:

Content of box for additive:

Blasting pressure with additive:

Blasting pressure w/o additive:

Dry ice consumption:

Additive consumption:

Max. power consumption:

Voltage:

Inlet hose connection:

frame and cover sheets made of powder-coated steel

752 x 608 x 1'103 mm (30 x 24 x 44 in)

approx. 110 kg (243 lb)

approx. 23 kg (51 lb)

approx. 12 kg (26 lb) (depending on additive)

4-8 bar (58-116 psi) (adjustable)

0-10 bar (0-145 psi) (adjustable)

25-80 kg/h (55-176 lb/h) (stepless)

up to 25 kg/h (55 lb/h) (depending on blasting pressure)

600 W (0.8 HP) nominal

230 V, 50 Hz, 1 Ph (other voltages on request)

3/4" BSP female

3/4" Claw coupling fitted

## ASCOJET 1708 Combi Blaster: Special features

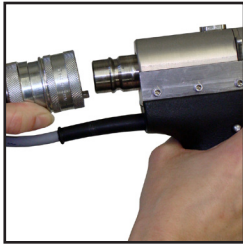

Powerful and handy blasting gun with quick connect coupling



Highly manoeuvrable



Integrated holding device for hose



Lightweight and compact

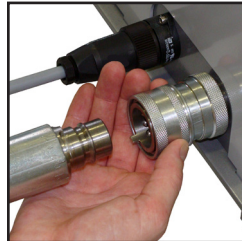

Quick connect coupling at blasting hose

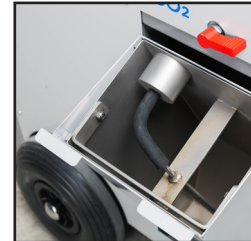

Box for additive with approx. 12 kg (26 lb) capacity

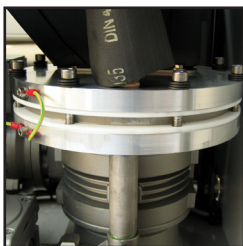

Distributor unit for pulsation-free blasting

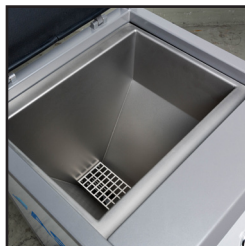

Insulated pellet hopper with 23 kg (50 lb) capacity



Control panel for easy overview

## ASCOJET 1708 Combi Blaster: Standard scope of supply

Pos. 001

### Blasting gun additive OHP

Standard for the ASCOJET 1708

Length: 29.5 cm (11.6 in)

Weight: 1.05 kg (2.3 lb)

Blasting pressure: 0 - 10 bar (0 - 145 psi)

incl. protection glove additive (part no. 4061690)

(Blasting gun OHP4 without nozzle part no. 4064796)

including the corresponding blasting nozzle

### Blasting nozzle additive OHP

Standard for the ASCOJET 1708

Special nozzle for combined blasting with dry ice and blasting sand

Outlet opening: approx. Ø 13 mm (0.5 in)

Length: 22.5 cm (8.9 in)

Inner diameter: 8 mm (0.3 in)

part no. 4063751



OHP

part no. 4061580



Pos. 002

### Hose assembly 7.5 m (24.6 ft) for OHP gun additive

Standard for the ASCOJET 1708

OHP

part no. 4061696



## ASCOJET 1708 Combi Blaster: Standard Scope of supply

Pos. 003

### Protective hood for ASCOJET 1701/1708

The newly developed hood for our blasting equipment protects the control elements from contamination. The transparent cover can be opened for easy view on and access to the operation elements. For cleaning the hood can easily be taken off.

part no. 4065213



Pos. 004

### Claw coupling with 19 mm (3/4") male thread

For fast connection and disconnection of the air line to the blasting equipment

Already mounted on the unit.

part no. 4045949



Pos. 005

### Power cable 10 m (32 in)

part no. 4053647

## ASCOJET 1708 Tool Case: Scope of supply

Pos. 001

### Tool case ASCOJET 1701 / 1708

Tool case complete  
(contains below articles pos. 002 - 008)

part no.. 4064572

OHP



os. 002

### Tool case ASCOJET 1701 / 1708 empty

Empty tool case with matching insert

part no. 4064575

OHP



Pos. 003

### High performance barrel nozzle 709.17/14

Powerful and handy nozzle

Outlet opening: approx. Ø 14 mm (0.6 in)

Length: 17 cm (6.7 in)

Inner diameter: 9 mm (0.4 in)

part no. 4045402

OHP



Pos. 004

### Barrel nozzle short 709.09/11

Powerful nozzle to clean in narrow spaces

Outlet opening: approx. Ø 11 mm (0.4 in)

Length: 9 cm (3.5 in)

Inner diameter: 9 mm (0.4 in)

part no. 4045403

OHP



## ASCOJET 1708 Tool Case: Scope of Supply

Pos. 005

### Barrel nozzle special 709.42/15

part no. 4047141

The nozzle is designed to allow for a comfortable working position of the person in charge and is very powerful

OHP



Outlet opening: approx. Ø 15 mm (0.6 in)  
Length: 42 cm (16.5 in)  
Inner diameter: 9 mm (0.4 in)

Pos. 006

### Angled nozzle 708.28/10/45°

part no. 4047222

A powerful nozzle for confined spaces with low air consumption

OHS  
OHP



Outlet opening: approx. Ø 10 mm (0.4 in)  
Length: 28 cm (11.0 in)  
Inner diameter: 8 mm (0.3 in)

Pos. 007

### Flat nozzle 709.23/45

part no. 4047216

Powerful nozzle suitable for blasting large areas

OHS  
OHP



Outlet opening: approx. 45 × 3.5 mm (1.77 x 0.14 in)  
Length: 23 cm (9.0 in)  
Inner diameter: 9 mm (0.3 in)

Pos. 008

### Lighting kit for dry ice blasting gun

part no. 4064129

Compact torch  
LED light 160 lumen, 160 cm (63 in)  
Up to 25 hours battery life (3 x 1.5V AAA)  
Batteries not included in scope of supply  
Length: 10.6 cm (4.2 in)  
Weight: 120 g (0.4 lb)

OHS  
OHP  
HP



## ASCOJET 1708: Options

Pos. 001

### High performance barrel nozzle 709.23/15

part no. 4047144

Powerful and handy nozzle  
Standard for the blasting gun OHP  
Most powerful nozzle of the ASCOJET single-hose system  
Outlet opening: approx. Ø 15 mm (0.6 in)  
Length: 23 cm (9.0 in)  
Inner diameter: 9 mm (0.4 in)

OHP



Pos. 002

### Angled nozzle 709.28/11/45°

part no. 4047219

A powerful nozzle for very confined spaces and difficult to reach spots

OHP



Outlet opening: approx. Ø 11 mm (0.4 in)  
Length: 28 cm (11.0 in)  
Inner diameter: 9 mm (0.4 in)

## ASCOJET 1708: Options

Pos. 003

### Angled nozzle 709.25/11/75°

A powerful nozzle for very confined spaces and difficult to reach spots

Outlet opening: approx. Ø 11 mm (0.4 in)  
Length: 25 cm (9.8 in)  
Inner diameter: 9 mm (0.4 in)

OHP

part no. 4047220



Pos. 004

### Pellet cutter OHP

For sensitive blasting applications

With safety quick connect coupling, 2.5 m (8.2 ft) hose and control cable, grounded

OHP

part no. 4047257



Pos. 005

### Converter coupling ASCOJET 1701 - 1208

This converter coupling makes it possible that the OHS gun with the corresponding blasting hose of the ASCOJET 1208 can be connected to the ASCOJET 1701

Length: 7.8 cm (3.0 in)  
Weight: 0.2 kg (0.4 lb)  
Outlet opening: approx. Ø 34 mm (1.3 in)

OHS

part no. 4047040



Pos. 006

### Blasting gun OHS

Standard for the ASCOJET 1208  
Length: 26 cm (10.2 in)  
Weight: 1.0 kg (2.2 lb)  
Blasting pressure: 0-7 bar (0-102 psi)

including the corresponding blasting nozzle  
**High performance barrel nozzle 707.15/12**

Standard for the blasting gun OHS  
Powerful nozzle with low air consumption  
Outlet opening: approx. Ø 12 mm (0.5 in)  
Length: 15 cm (6.0 in)  
Inner diameter: 7 mm (0.3 in)

OHS

part no. 4063745



part no. 4047321



Pos. 007

### Hose assembly 5 m (16.4 ft) for OHS gun

Standard for the ASCOJET 1208, can also be used as an extension of the hose assembly  
incl. control cable, grounded

OHS

part no. 4047104



Pos. 008

### Nozzle extension 700.150 OHP/OHS

Modular nozzle extension for OHS and OHP dry ice blasting guns with a total length of up to 1.5 m (59 in) with nozzle

Length 1: 455 mm (18 in) without nozzle  
Length 2: 580 mm (23 in) without nozzle  
Length 3: 835 mm (33 in) without nozzle  
Length 4: 960 mm (38 in) without nozzle  
Length 5: 1340 mm (53 in) without nozzle

Weight in full length: 1.50 kg (3.3 lb)  
Inner diameter: 10 mm (0.4 in)  
Material: aluminium

OHS  
OHP

part no. 4046018



## ASCOJET 1708: Options

Pos. 009

### Barrel nozzle 707.09/10

Thanks to an inner diameter of only 7 mm (0.27 in) the barrel nozzle has a very economical air consumption but is nevertheless powerful

Outlet opening: approx. Ø 10 mm (0.4 in)  
Length: 9 cm (3.5 in)  
Inner diameter: 7 mm (0.3 in)

OHS  
OHP

part no. 4047228



Pos. 010

### High performance barrel nozzle 707.15/12

Standard for the blasting gun OHS  
Powerful nozzle with low air consumption  
Outlet opening: approx. Ø 12 mm (0.5 in)  
Length: 15 cm (6.0 in)  
Inner diameter: 7 mm (0.3 in)

OHS  
OHP

part no. 4047321



Pos. 011

### Angled nozzle 708.25/10/75°

A powerful nozzle for confined spaces with low air consumption

Outlet opening: approx. Ø 10 mm (0.4 in)  
Length: 25 cm (9.8 in)  
Inner diameter: 8 mm (0.3 in)

OHS  
OHP

part no. 4047223



Pos. 0012

### Nozzle extension 700.62 OHP/OHS

Modular for nozzle extension for OHS and OHP dry ice blasting guns with a length of 668 mm (26.3 in)

Weight: 0.6 kg (1.3 lb)  
Inner diameter: 10 mm (0.4 in)  
Material: aluminium

OHS  
OHP

part no. 4063373



Pos. 013

### Spare parts kit ASCOJET 1708 Combi Blaster

Includes a recommended selection of spare parts to ensure constant operation.

part no. 4066289



Sample image

## ASCOJET 1708: Options

Pos. 014

### Compressed air hose 7.5 m (24.6 ft) / ID 25 mm (1 in)

Connecting hose between air compressor and dry ice blasting machine, incl. claw coupling and safety ring for fast and easy connection / disconnection

Material: Fabric hose / metal

Dimension: 7.5 m (24.6 ft)

Weight: 2.4 kg (5.3 lb)

part no. 4045955



Pos. 015

### Protective sleeve for one hose system 165 mm (6.5 in)

To protect the control cable and blasting hose from dirt and damages

Available in meters

part no. 4047265







The ASCO logo features the company name in a bold, blue, sans-serif font. To the left of the text is a stylized graphic consisting of three horizontal blue bars of varying lengths, stacked vertically, resembling a pressure gauge or a valve handle.

All about CO<sub>2</sub>



**Head Office**

ASCO CARBON DIOXIDE LTD  
Industriestrasse 2, CH-8590 Romanshorn  
T +41 71 466 80 80 / F +41 71 466 80 66  
info@ascoco2.com / ascoco2.com

**Subsidiary Germany**

ASCO KOHLENSÄURE AG  
Sprudelstrasse 3, DE-53557 Bad Honningen  
T +49 2635 92 534-0  
F +49 2635 92 534 192

**Subsidiary USA**

ASCO CARBON DIOXIDE INC  
80-4 Industrial Loop North, Orange Park, FL 32073  
T+1 904 374 9590 / Toll free +1 877 633 0996  
usa@ascoco2.com